

# Instruction Manual

---

## Instruction Manual Thermocouple Gauge Control Units Models TCG-531 & TCG-531/2 Models TCG-06M & TCG-06M/2



Copyright © 1998 by Duniway Stockroom Corp.

rev083010sr

## **Table of Contents**

---

<b>I Technical Specifications</b>	<b>page 4</b>
<b>II Principle of Operation</b>	<b>page 5</b>
<b>III Installation</b>	<b>page 7</b>
<b>IV Operation/Calibration</b>	<b>page 8</b>
<b>A. Operation</b>	
<b>B. Calibration</b>	
<b>V Accessing Analog Voltage/Pressure Signal</b>	<b>page 9</b>
<b>VI Maintenance</b>	<b>page 10</b>

## List of Illustrations

---

Figure 1: Diagram of Thermocouple Tube and Control Unit	page 5
Figure 2: TCG-531 Figure 3: TCG-06M/2 with Box	page 6
Figure 2: TCG-531 Figure 3: TCG-06M/2 with Box	page 6
Figure 4: Photograph of Control Unit - Side and Front	page 7
Figure 5: Rear View of Meter, Showing Output Terminals	page 9
	page 9
Figure 6: Dis-assembled Unit	page 10
Table 2: Cross Reference/Equivalent List	page 11
Figure 7: Panel Mounting Holes for TCG Meter	page 11
Figure 8: Thermocouple Control Unit Schematic Diagram	page 12
Table 3: Component Values for Figure 7, Schematic	page 12

## I Technical Specifications

Input Voltage:	110 VAC, 50/60 Hz (for other power requirements consult Duniway Stockroom Corp.)
Weight:	1 lb (0.5 kg)
Range:	1 millitorr to 2000 millitorr
Environmental limits:	32-120°F (0-49°C) 10%-90% Relative Humidity, Non-Condensing -1000 feet (-333 meters) to +10,000 feet (+3333 meters) altitude
Dimensions:	3.5 inches high (8.9 cm) 4.1 inches wide (10.4 cm) 3.1 inches deep (7.9 cm)
Power Cable Length:	6 feet (183 cm)
Thermocouple Cable Length:	10 feet (305 cm)

## II Principle of Operation

Thermocouple gauges belong to the class of vacuum gauges which rely on the thermal transport qualities of gases. The thermocouple gauge uses the thermal conductivity property of gases, by incorporating a wire filament which is heated by a constant source of power. Attached to this filament is a thermocouple, which measures the temperature of the wire. At high pressures, the large number of gas molecules striking the heated wire carries energy away and cools the wire. At low pressures, the smaller number of gas molecules striking the wire causes less cooling, and thus a higher temperature. The thermocouple output voltage responds to these temperature changes to give an indication of pressure: low gas pressure gives high filament temperature which gives high thermocouple output voltage; high gas pressure gives low filament temperature which gives low thermocouple output voltage. The meter measuring the thermocouple voltage is calibrated in pressure units to give a direct indication of pressure.

At pressures below about  $10^{-3}$  torr, the heat loss from the filament is primarily through radiation since the density of gas molecules is so low. Since the heat loss due to radiation is constant, the resulting temperature corresponds to the "zero" reading on the meter.

The thermocouple gauge is a simple, rugged device which is very useful at rough vacuum pressures. The meter covers the pressure range of 1 to 2000 millitorr.

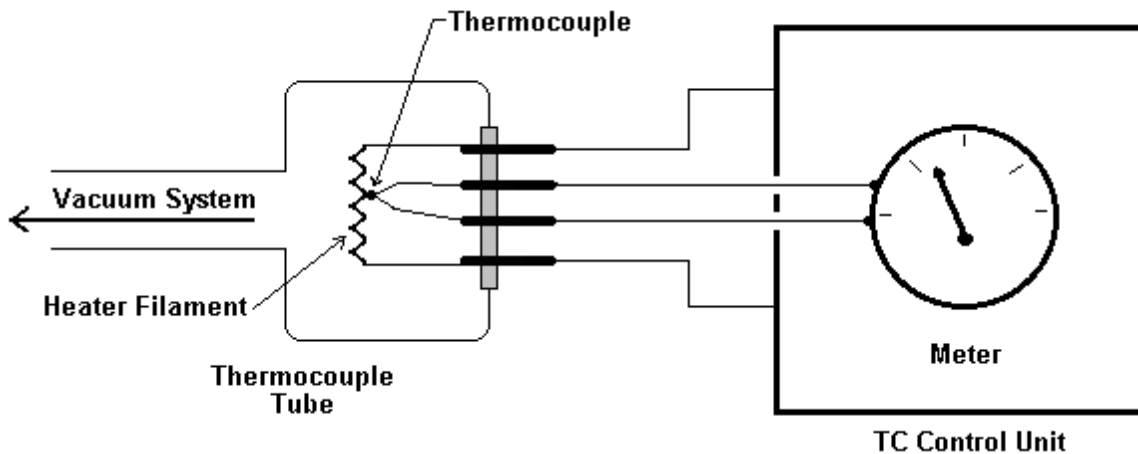

**Figure 1: Diagram of Thermocouple Tube and Control Unit**

Two different basic models are available to support either the Varian Type 531 tube or the Hastings type DV-6M tube. For the TCG-531, a thermistor temperature compensation device is built into the thermocouple connector for added stability. Each type is also available in a version to support two thermocouple tubes.

Shown below are photographs of two examples, Figure 2 shows a TCG-531 and Figure 3 shows a model TCG-06M/2 mounted in a box. See the table under Section V "Maintenance" for a cross reference list for compatibility of various manufacturer's tubes and Duniway Stockroom Corp. control units.



**Figure 2: TCG-531**

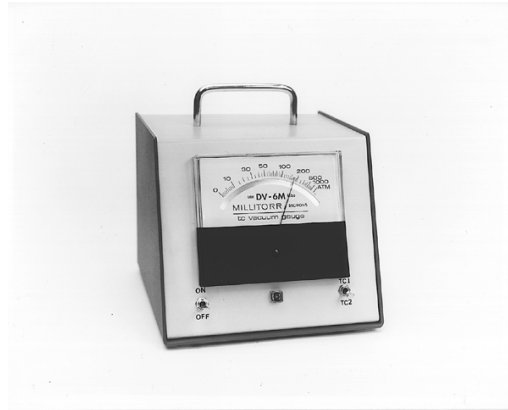

**Figure 3: TCG-06M/2 with Box**

**NOTE: Thermocouple Gauges should not be operated in conditions where significant amounts of flammable gases are present; for example: Methane, ethane, acetylene, etc.**

### III Installation

The basic thermocouple controller is a self-contained meter/control/cable package. The unit assembly consists of a meter, power unit, 6 foot power cable and 10 foot thermocouple cable. It can be operated as a free-standing unit, or can be panel mounted. An optional box is available separately for mounting the unit.

#### Installation involves

1. Mounting of the unit, if required.
2. Attach the thermocouple cable to the thermocouple tube.
3. Adjust mechanical zero, if required. The mechanical zero adjust is located on the lower front of the meter face.
4. Plug in the power cable.

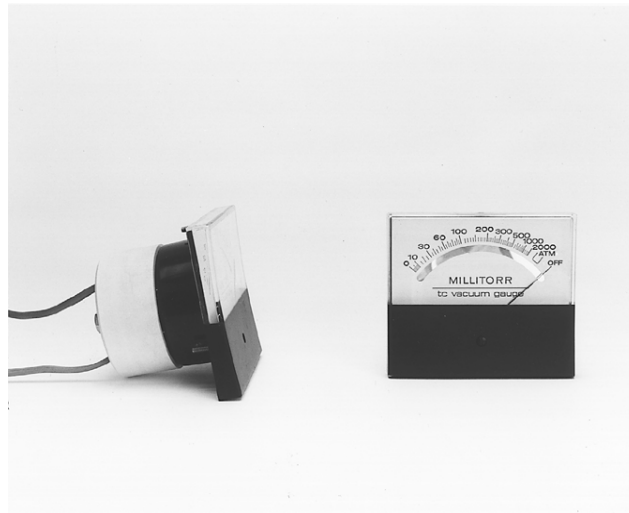

**Figure 4: Photograph of Control Unit - Side and Front**

## IV

## Operation/Calibration

### A. Operation

Operation of the thermocouple gauge and control is generally very simple and trouble free. Occasional mechanical zero adjustment and calibration may be required. See "Maintenance" for additional information.

### B. Calibration

Introduction Initial matching of a tube to a control unit and long term changes to the sensing elements require the performance of the calibration steps described below. New units ordered with a sensor tube from Duniway Stockroom are calibrated at the factory.

1. With the line power disconnected, adjust the mechanical meter zero until the needle indicates "OFF" (Full scale).
2. Connect the thermocouple tube, matched to the control unit, to a vacuum system capable of reaching and maintaining a pressure of less than 1.0 micron (1 millitorr).
3. Pump down the system until the pressure is below 1.0 micron (1 millitorr).
4. Connect the thermocouple cable of the Duniway Stockroom Corp. control unit to the thermocouple gauge tube.
5. Plug the line cord into a 115 VAC 50/60 Hertz outlet.
6. Locate the calibration control adjustment screw on the back of the control unit and adjust it until the meter reads zero millitorr.
7. Allow the system to stabilize for approximately 15 minutes, and readjust the zero if necessary.

#### *NOTE*

If more accurate calibration is required, the gauge can be calibrated against an absolute pressure gauge, such as a McLeod gauge.



## V Accessing Analog Voltage/Pressure Signal

The TCG-531 and TCG-06M are equipped with terminals which provide access to an analog voltage output signal related to the indicated pressure. Figure 5, below, shows a rear view of the meter with the analog voltage output terminals indicated by + and -.

For the TCG-531 with BOX and the TCG-06M with BOX, access to the analog voltage output signal can be accomplished by following the dis-assembly instruction sin Section VI - Maintenance

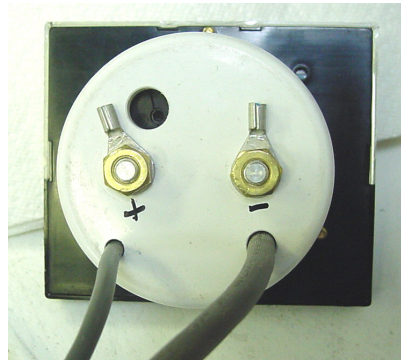

**Figure 5: Rear View of Meter, Showing Output Terminals**

The relationship between pressure and analog voltage is shown below in Table 1.

<b>TCG-531</b>			<b>TCG-06M</b>	
<b>Pressure Scale Reading millitorr</b>	<b>Meter Output Voltage millivolts</b>		<b>Pressure Scale Reading millitorr</b>	<b>Meter Output Voltage millivolts</b>
<b>OFF</b>	<b>0.0</b>		<b>DOT</b>	<b>0.00</b>
<b>2000</b>	<b>1.8</b>		<b>ATM</b>	<b>0.22</b>
<b>500</b>	<b>3.2</b>		<b>1000</b>	<b>0.56</b>
<b>200</b>	<b>5.2</b>		<b>500</b>	<b>1.02</b>
<b>100</b>	<b>7.1</b>		<b>200</b>	<b>2.25</b>
<b>30</b>	<b>8.4</b>		<b>100</b>	<b>3.80</b>
<b>0</b>	<b>11.0</b>		<b>50</b>	<b>5.55</b>
			<b>10</b>	<b>8.56</b>
			<b>0</b>	<b>10.00</b>

**Table 1: Analog Output Voltage vs. Pressure**

## VI Maintenance

Aging and/or contamination can change the calibration of the thermocouple gauge, thus recalibration may be necessary from time to time.

The sensitivity of thermocouple gauges varies significantly from one gas species to another and with pressure for a specific gas. For example, the sensitivity of a thermocouple gauge for helium is higher than for air at intermediate pressures, but lower at high pressures.

If disassembly of the gauge control should become necessary, the following procedure should be followed.

1. Unplug the line power cord.
2. Unplug the thermocouple gauge tube.
3. Remove the two nuts from the back of the unit.
4. Remove the white plastic cover from the unit.
5. Remove the printed circuit board from the meter  
(See the photo below and schematic diagram)

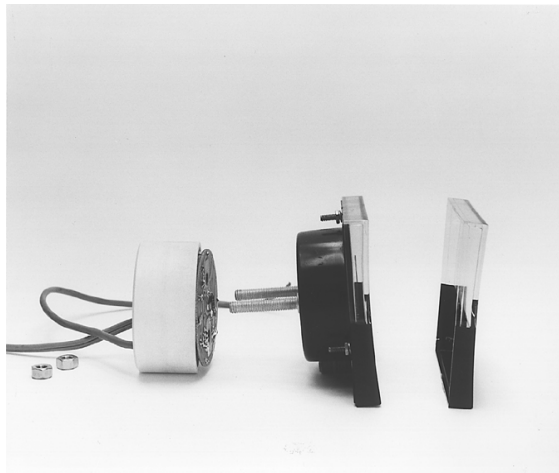

**Figure 6: Dis-assembled Unit**

### **Warranty:**

These thermocouple control/display products are warranted against defects in material and workmanship for 90 days from date of delivery.

If you need to return a unit for repair, please call one of the numbers at the bottom of this page to request a Returned Material Authorization (RMA) number.

rev531059sr

<u>Duniway Part #</u>	<u>Hastings Part #</u>	<u>Hastings Base Color</u>	<u>Veeco Part #</u>	<u>CVC Part #</u>	<u>Varian Part #</u>	<u>GP Part #</u>
DST-01M	DV-3M	BLACK	DV-1M	-	-	-
DST-04D	DV-4D	PURPLE	DV-4M	-	-	-
DST-06M	DV-6M	YELLOW	-	-	-	270-006
DST-023	DV-23	ORANGE	-	-	-	-
DST-004	-	-	-	GTC-004	-	-
DST-036	-	-	-	GTC-036	-	-
DST-531	-	-	-	-	0531-F0472-301	-
DST-531S	-	-	-	-	0531-F0472-303	-
DST-1518	(MDC	TGT-1518	&	HML	TCT-1518)	

**Table 2: Cross Reference/Equivalent List**

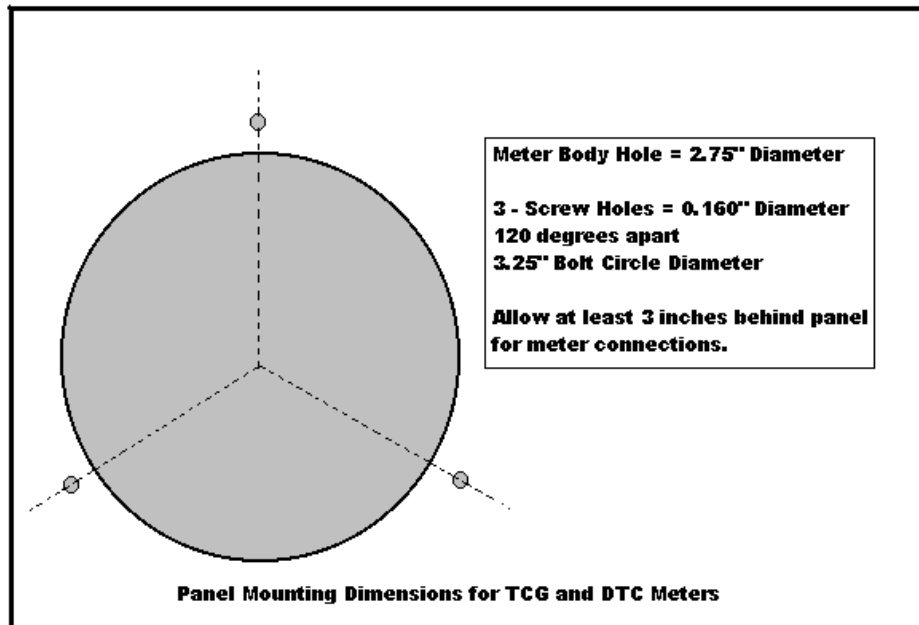

**Figure 7: Panel Mounting Holes for TCG Meter**

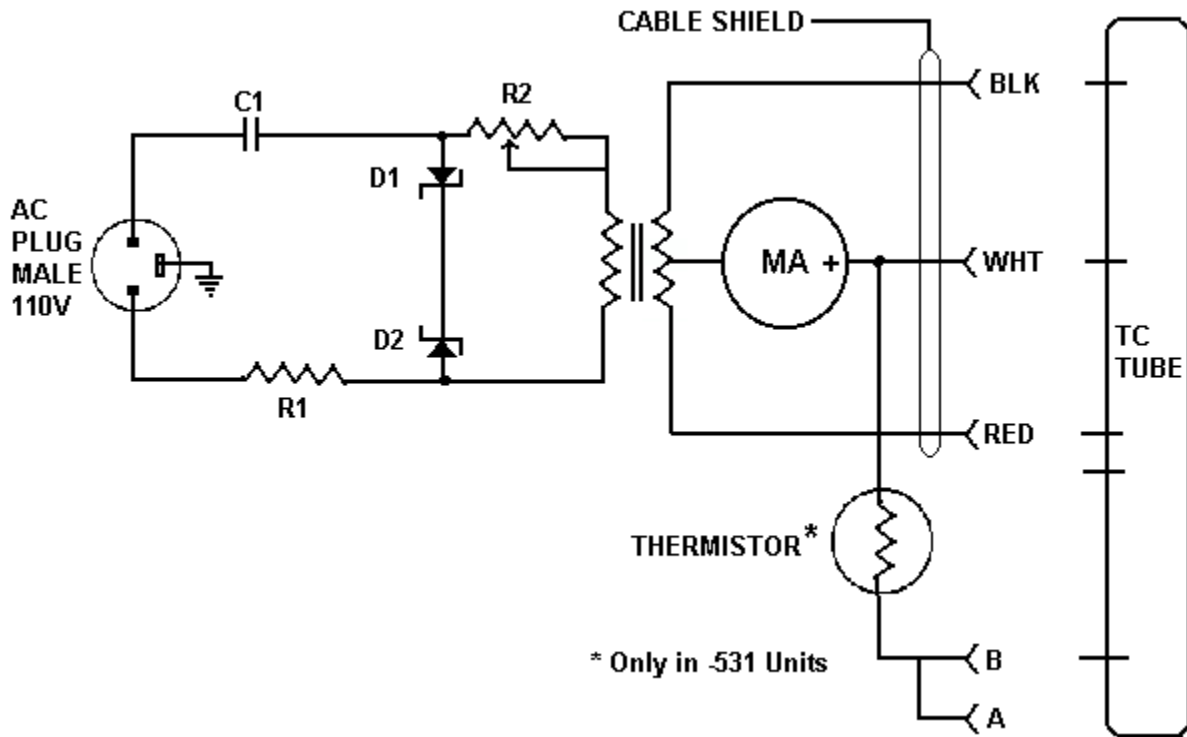

**Figure 8: Thermocouple Control Unit Schematic Diagram**

Unit Type	C1	R1	R2	D1	D2	RED	WHT	BLK	A	B
-531	2 micro f. 200v	33 ohm 2W	150 ohm 2W	6.8 volt 5W	6.8 volt 5W	# 7	# 2	# 3	# 5	# 1
-06M	2 micro f. 200v	33 ohm 2W	350 ohm 2W	7.5 volt 5W	7.5 volt 5W	# 5	# 7	# 3	NA	NA

**Table 3: Component Values for Figure 7, Schematic**