

Instruction Manual

TERRANOVA[®]

Model 809 Diaphragm Gauge Controller

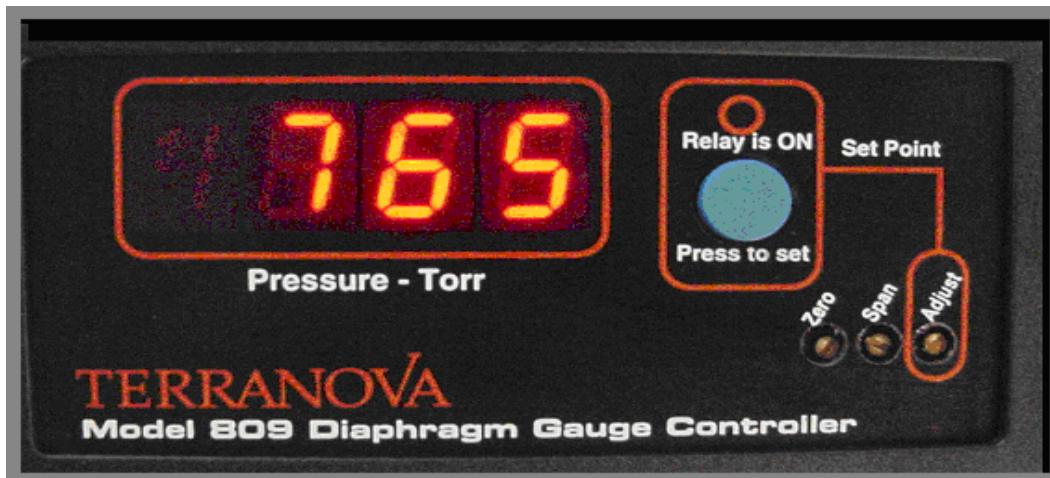

Copyright © 2004 by Duniway Stockroom Corp.
rev120313sr

Table of Contents

I	Safety Information	page 4
II	Overview	page 5
	A. Front View, Back View and Dimensions	
	B. General Description	
	C. Specifications	
	D. Controls and Indicators	
	C. Diaphragm Gauge Suppliers	
III	Installation	page 8
	A. Unpack the Controller	
	B. Mount the Controller	
	C. Select the Diaphragm Gauge	
	D. Connect the Diaphragm Gauge	
	E. Attach the Diaphragm Gauge Cable	
	F. Make Accessory Connections	
	G. Check Supply Voltage	
	H. Attach the Power Cord	
IV	Operation	page 12
	A. Turn Power On	
	B. Front Panel Controls	
	C. Set Point Adjust	
	D. Set Point Operation	
	E. Span	
	F. Zero	
	G. Reading Pressure; Setting the Position of the Decimal Point	
	H. Analog Output	
V	Maintenance	page 15
	A. Changing Fuses	
	B. Schematic Diagrams	
VI	Trouble Shooting	page 16
VII	Warranty	page 17

List of Figures

Figure 1:	Model 809 front view	page 5
Figure 2:	Model 809 rear view	page 5
Figure 3:	Model 809 dimensions	page 5
Figure 4:	Sensor Connector -- 9 Pin Female D-Sub	page 9
Figure 5:	Duniway 808 Si Diaphragm Pin Connections	page 9
Figure 6:	MKS Baratron Pin Connections (15 pin)	page 10
Figure 7:	MKS Baratron Pin Connections (5 pin)	page 10
Figure 8:	MKS Baratron Pin Connections (9 pin 'D')	page 10
Figure 9:	Accessory Connector -- 15 Pin Female D-Sub	page 11
Figure 10:	Accessory Connector Signals and Pins	page 11
Figure 11:	Analog Output and Displayed Pressure	page 14

I Safety Information

Limitation on use of Compression Mounts



WARNING!

Do not use a compression mount (quick-connect) for attaching the gauge tube to the vacuum system in applications that may develop positive pressures. Positive pressures may cause the tube to be blown out of a compression fitting and damage equipment and injure personnel.

Please let us Know...

Terranova products are the most advance instruments of their type available from any manufacturer. We have made this Instruction Manual as complete and clear as possible. Let us know if you have any comments that can make this manual or our products more useful.

II

Overview

A. Front View, Back View and Dimensions

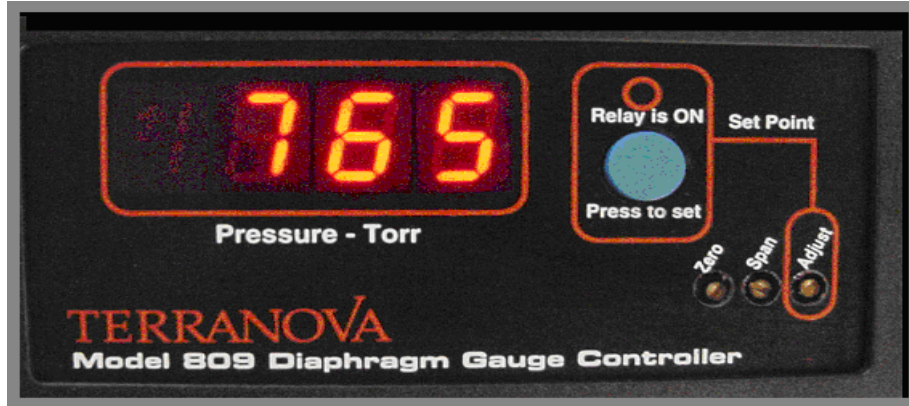

Figure 1: Model 809 front view

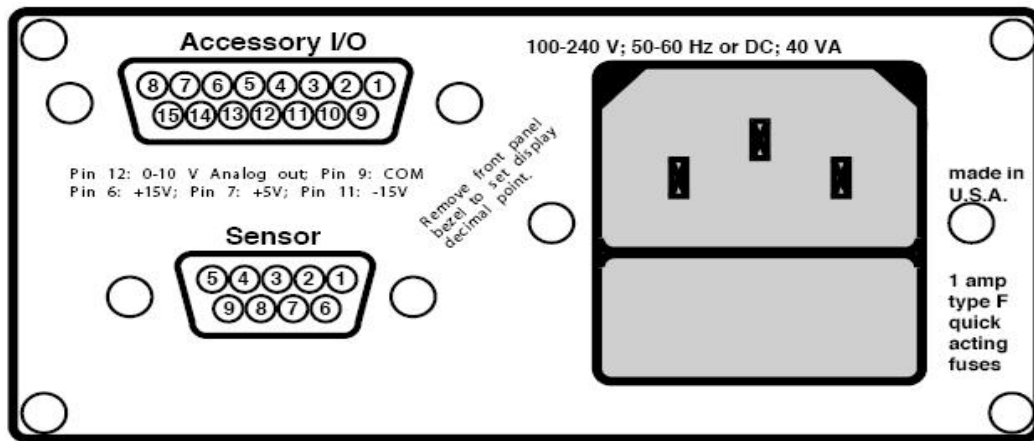

Figure 2: Model 809 rear view

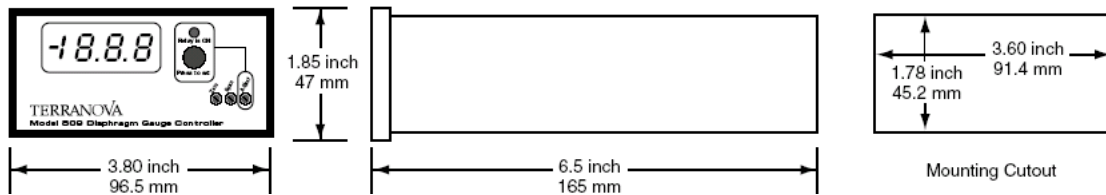

Figure 3: Model 809 dimensions

B. General Description

The Terranova Model 809 Diaphragm Gauge Controller displays vacuum pressure as measured from diaphragm gauges. The 809 supplies ± 15 volts to operate un-heated diaphragm gauges and precisely measures the 0 to 10 volt signal from the Diaphragm Gauge to determine pressure. The 809 is housed in a 1/8 DIN enclosure and is simple to operate.

C. Specifications

1. Useful Measuring Range
3+ decades; for Diaphragm Gauge tubes with full scale of 1000 Torr, 100 Torr, 10 Torr, 1 Torr and 100 mTorr. Decimal point location selection is entered on the front panel by the user
2. Display Range
0.001 torr to 1000 torr.
3. Display Resolution
resolution is 0.1% of the full scale range, e.g. 1 Torr resolution for 1000 Torr full scale range.
4. Gauge Interface
The 809 incorporates a high-resolution input circuit which allows the use of the diaphragm gauge over its entire 4 decades.
5. Input to the 809 Controller
0 to 10 volts DC for full scale of the gauge
(input greater than 10.5 VDC results in display of "1" in left-most digit).
6. Units of Display
torr
7. Full Scale
user selectable decimal point position: XXX, XX.X, X.XX or .XXX.
8. Vacuum Gauge
one linear diaphragm gauge which has 0-10 VDC signal output and require ± 15 volt power.
9. Process Control Set Points
one set point relay, contacts rated at:
2 amp @ 30VDC resistive
1 amp @ 120VAC resistive
0.5 amp @ 240VAC resistive
10. Analog Output
linear, 0-10 V buffered output corresponds to zero to full-scale for attached gauge

11. Mounting

The 809 may be used as a bench-top instrument or it may be mounted in an instrument panel. Clips are provided for panel mounting.

12. Operating Voltage

The Model 809 has a universal power supply, which operates on input voltages from 90 VAC to 240 VAC 47 to 65 Hz; input is through a standard IEC 320 instrument power input receptacle on the rear panel; input power is protected by fuses in both lines of the input power.

13. Weight, Model 809 only; does not include cable or Diaphragm Gauge

0.9 lb. /0.4 kg

D. Controls and Indicators

1. ZERO, SPAN and SET POINT ADJUST screw-driver slots used for adjustment of gauge and instrument parameters
2. Digital Display - Pressure
3+digit (1XXX) 7-segment bright red LED, 10 mm high
3. SET POINT ADJUST Button and LED Indicator
bright red individual LED

E. Diaphragm Gauge Suppliers

Diaphragm Gauges may be ordered from several sources, including the following:

Duniway Stockroom Corp.

48501 Milmont Drive

Fremont, CA 94538

USA

telephone (650) 969-8811

toll-free (800) 446-8811

facsimile (650) 965-0764

E-mail info@duniway.com

internet www.duniway.com

MKS Instruments, Inc.

Six Shattuck Rd.

Andover, Massachusetts 01810

USA

telephone (978) 975-2350

toll-free (800) 227-8766

facsimile (978) 975-0093

internet www.mksinst.com

III Installation

A. Unpack the Controller

Carefully unpack the Model 809 Diaphragm Gauge Controller. The shipment includes these components:

- controller unit
- power cord
- mounting clips
- D-sub 15 accessory connector
- this instruction manual

If your controller does not have all of these items, call Duniway Stockroom. If anything appears to have been damaged in shipment, contact the shipper. For Diaphragm Gauge sensor tubes and cables, please see the Duniway Stockroom Corp. latest catalog or our web site.

Do not plug the power cord in yet.

B. Mount the Controller

You can rest the controller unit on a bench, table top, or shelf, or you can mount it in a rack or cabinet. The controller unit is housed in a standard 1/8 DIN box. If you are mounting the unit in a panel, the cutout dimensions are 1.78 inch by 3.60 inch (45.2 mm by 91.4 mm), see fig. 3, page 9. One mounting clip attaches to each of the sides of the controller unit. To attach the clip, slide the beveled surfaces of the clip under the cutout on the side of the box and push the clip toward the back of the unit.

Be sure to leave enough clearance at the back of the controller unit for easy access to cable connections.

C. Select the Diaphragm Gauge

The Model 809 controller is designed to work with standard, unheated diaphragm gauges, such as the Duniway Stockroom Si Diaphragm Gauge or the MKS Baratron^(tm) which operate on +13 to 32 VDC. If you have difficulty obtaining a Diaphragm Gauge, please contact us at Duniway Stockroom.

CAUTION

Use of a Diaphragm Gauge other than those which operate from +13 to 32 VDC may cause damage to the Diaphragm Gauge.

D. Connect the Diaphragm Gauge

Make sure that the Diaphragm Gauge is securely connected to the vacuum system, using good vacuum practice.

E. Attach the Diaphragm Gauge Cable

The Diaphragm Gauge cable has a 9-pin D-sub connector on one end, which plugs into the 809, see Figure 4, below. There are a variety of conventions for connection to the Diaphragm Gauge; you may assemble or modify the cable to adapt to the Diaphragm Gauge as needed. Connect the 9-pin D-sub plug of the gauge cable to the 9-pin connector on the back of the 809 controller unit. Push the plug onto the connector until it is firmly in place. Tighten the retaining screws to make certain the connector remains in place. Loose connections can cause faulty readings.

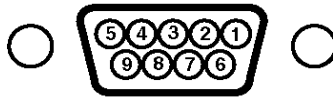

Figure 4: Model 809 Sensor Connector -- 9 Pin Female D-Sub Connector

NOTE

The following information will allow you to make modifications to the cable as needed to interface with your Diaphragm Gauge. Please refer to Figure 4 above; this shows the 9-pin connector which is on the rear panel of the 809. This connector has female sockets; the mating connector on the Diaphragm Gauge cable must have male pins

809 9-pin 'D'		to Duniway 808 Si Diaphragm 15 pin 'D'	
<u>809 Pin</u>	<u>Terranova Name</u>	<u>Color</u>	<u>Tube Pin/Connection Name</u>
1	Tube Signal	white	to: Pin 2/Signal Output
2			
3			
4	+15 volts	red	to: Pin 7/+15 VDC
5			
6	-15 volts	green	to: Pin 6/-15 VDC
7			
8	Tube Signal Return	brown	to: Pin 12/Signal Common
9	Electronics Common	black/shield	to: Pins 5/Pwr.Comm & 15/& Chassis Gnd
9			

(The Duniway Part Number for this cable is: 8100-0908-012)
Figure 5: 809 - Duniway 808 Si Diaphragm Pin Connections

809 9-pin 'D'			to MKS Baratron 15-pin 'D'	
<u>809 Pin</u>	<u>Terranova Name</u>	<u>Color</u>	<u>Tube Pin/Connection Name</u>	
1	Tube Signal	white	to:	Pin 2/Signal Output
2				
3				
4	+15 volts	red	to:	Pin 7/+15 VDC
5				
6	-15 volts	green	to:	Pin 6/-15 VDC
7				
8	Tube Signal Return	brown	to:	Pin 12/Signal Common
9	Electronics Common	black/shield	to:	Pins 5/Pwr.Comm & 15/& Chassis Gnd
9				

Figure 6: 809 -- MKS Baratron Pin Connections (15 pin)

809 9-pin 'D'			to MKS Baratron 5-pin Molex	
<u>809 Pin</u>	<u>Terranova Name</u>	<u>Color</u>	<u>Tube Pin/Connection Name</u>	
1	Tube Signal	white	to:	Pin 3: Pressure Out
2				
3				
4	+15 volts	red	to:	Pin 5: +15 VDC
5				
6	-15 volts	green	to:	Pin 4: -15 VDC
7				
8	Tube Signal Return	brown	to:	Pin 2: Output Return
9	Electronics Common	black/shield	to:	Pin 1: Pwr.Comm
9				

Figure 7: 809 -- MKS Baratron Pin Connections (5 pin)

809 9-pin 'D'			to MKS Baratron 9-pin 'D' (i.e. 750B)	
<u>809 Pin</u>	<u>Terranova Name</u>	<u>Color</u>	<u>Tube Pin/Connection Name</u>	
1	Tube Signal	white	to:	Pin 1/Pressure Out
2				
3				
4	+15 volts	red	to:	Pin 4/+15 VDC
5				
6				
7				
8	Tube Signal Return	brown	to:	Pin 8/Output Return
9	Electronics Common	black/shield	to:	Pin 9/Pwr.Comm & none
9				

Figure 8: 809--MKS Baratron Pin Connections (9 pin 'D')
(This applies to Diaphragm Gauge sensor tubes such as the Baratron 750B)

F. Make Accessory Connections

The 15-pin D-sub Accessory Connector is on the rear panel of the 809, see Figure 8, below. The connector has female pins; the mating connector must have male pins. Mating D-sub 15 connectors are available from many of the normal electronic sources. If you need help identifying a source, please contact us.

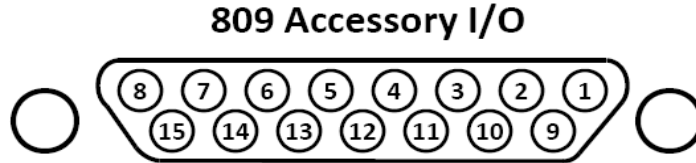

Figure 9: Model 809 Accessory Connector -- 15 Pin Female D-Sub Connector

Following are pin assignments for the 15 Pin D-Sub Accessory Connector:

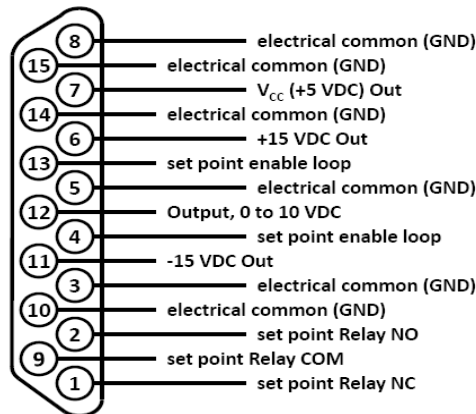

Figure 10: 809 -- Accessory Connector Signals and Pins

G. Check Supply Voltage

The Model 809 incorporates a universal power supply. This allows the 809 to operate on any input voltage from 90 VAC to 240 VAC, 47 to 65 Hz.

H. Attach the Power Cord

Plug the power cord into the receptacle in the power module on the rear of the 809.

IV **Operation**

A. Turn Power On

Plug the AC power end of the power cord into an electrical outlet. The 809 will go into normal operation and begin measuring pressure. If a Diaphragm Gauge is not connected or if the pressure signal voltage is higher than 10.5 VDC, the display will show “1” in the left-most position of the display.

B. Front Panel Controls

The Model 809 allows adjustment using simple entry from the front panel. Following is a detailed description of parameter selection and adjustment:

C. Set Point Adjust

The Set Point adjustment screw is located on the lower right hand corner of the front panel, see Figure 1. You will need a small-blade screw driver to adjust the set point. This adjustment sets the threshold at which the setpoint relay changes state; above this pressure the relay will be de-energized. To adjust the set point pressure, press the blue button labelled “Press to Set” on the front panel. The digital display will show the set point value. Adjust the set point screw to change the value.

D. Set Point Operation

When pressure values have been entered for the set point, the set point relay operates as follows:

As the pressure on the assigned gauge falls through the chosen “Set Point” pressure, the relay actuates, either opening (if the Normally Closed pin has been used on the Auxiliary I/O connector) or closing (if the Normally Open pin has been used on the Auxiliary I/O connector).

Likewise, as the pressure on the gauge rises through the chosen “Set Point” pressure plus 0.3% of full scale, the relay de-actuates, either closing (if the Normally Closed pin has been used on the Auxiliary I/O connector) or opening (if the Normally Open pin has been used on the Auxiliary I/O connector).

For example, if the full scale range is 1000 torr and the set point is set to 100 torr, the set point relay will actuate as the pressure falls to 100 torr or lower and the LED labelled “Relay is On” will be illuminated. When the pressure rises to above 103 torr (approximately), the relay will be de-activated and the LED will go off.

NOTE: In order to make the set point relay function, it is necessary to add a simple external loop to enable the relay. This loop is a connection from pin 4 (Set Pt. Enable Loop) of the D15 Accessory I/O Connector (see page 11) to pin 13 (Set Pt. Enable Loop) of the same connector. Without this jumper/loop connection, the relay and set point function will not operate.

E. Span

This allows the user to adjust the Controller and Sensor at some known pressure, such as Atmospheric pressure. Adjust the “SPAN” screw on the front panel to change the value. For a 1000 Torr full scale Diaphragm Gauge, consult with your local airport or go to www.weather.com to determine the current, local atmospheric pressure.

F. Zero

This allows the user to adjust the zero of the Controller independent of the Sensor. Before making this adjustment, the Diaphragm Gauge should be connected to a vacuum system at a pressure lower than 0.01% of the full scale for the Diaphragm Gauge.

Adjust the zero adjustment on the Diaphragm Gauge (usually a trimpot) until the 809 display shows a value close to zero. After this initial adjustment, the display may be conveniently set to zero using “ZERO” screw on the front panel.

G. Reading Pressure; Setting the Position of the Decimal Point

The Digital Display shows three digits plus “1”, when appropriate, in the left-most position. Depending on the Full-Scale sensitivity of the diaphragm sensor being used, the decimal point can be manually changed to display the correct pressure.

To change the position of the decimal point on the display:

1. Remove the bezel which holds the front panel on the 809 by applying gentle force forward on the corners of the bezel.
2. Immediately below the blue button, you will find a set of microswitches mounted on a small red block.
3. The microswitches are OFF when the lever is in the upward position and ON when the lever is in the lower position.

The decimal point position is set as follows:

For 1000 torr full scale diaphragm sensor tubes: All three microswitches up (OFF), no decimal point is displayed. The display is read: XXXX torr.

For 100 torr full scale diaphragm sensor tubes: Right-most only of the three switches is down (ON), the decimal point is displayed between the third and fourth numbers on the display. The display is read: XXX.X torr.

For 10 torr full scale diaphragm sensor tubes Center only of the three switches is down (ON), the decimal point is displayed between the second and third numbers on the display. The display is read: XX.XX torr.

For 1 torr full scale diaphragm sensor tubes: Left-most only of the three switches is down (ON), the decimal point is displayed between the first (“1”) and second numbers on the display. The display is read: X.XXX torr.

For 100 mtorr full scale diaphragm sensor tubes: Right-most only of the three switches is down (ON), the decimal point is displayed between the third and fourth numbers on the display. The display is read: XXX.X mtorr.

ATTENTION: For sensor tubes with less than 1000 torr full scale range, the sensor output at atmospheric pressure will exceed 10.5 VDC and the display will show “1” in the left-most digit.

NOTE: While it is possible to have more than one decimal point position micro-switch in the ON position, it has no meaning and may confuse the user of the system.

H. Analog Output

The analog output is 0-10 volts, where 10 volts represents the full-scale reading of the diaphragm gauge selected. In the table below, the data is given for a 1000 torr full scale diaphragm gauge. The data can be scaled for other full scale ranges.

<u>Displayed pressure</u>	<u>Analog Output - volts</u>
0 Torr or less	0.00
10.0 Torr	0.10
50.0 Torr	0.50
100 Torr	1.00
327 Torr	3.27
1000 Torr	10.00

Figure 11: Analog Output and Displayed Pressure (1000 torr FS Diaphragm Gauge)

V Maintenance

A. Changing Fuses

The controller contains two fuses. Both fuses are held in the fuse assembly that is part of the power module located on the back panel of the controller. To change fuses, unplug the line cord from the power entry module at the rear of the 809; locate the fuse block immediately below the line cord socket. Press the tab of the fuse assembly and withdraw the fuse assembly from the power module.

Turn the fuse assembly around so that the fuses are facing you. Check both fuses; replace the burnt-out fuse with a fuse of the appropriate rating (refer to **Specifications** section). Reinsert the fuse assembly into the power module; push it in until the ears click into place.

Replacement fuse type: 5 mm X 20 mm, regular or slow-blow 1 amp

<u>manufacturer</u>	<u>fuse type</u>
Bussman	GDB-1A or GDC-1A
Littlefuse	217 001 or 218 001

B. Schematic Diagrams

Because of the proprietary nature of our products, we do not supply schematic diagrams or software listings. If you have any problem with operation or interface to any of our products, please contact us; we will do everything we can to serve your needs.

VI **Trouble Shooting Return Procedure**

Trouble Shooting

If fuses burn out, check to see that the proper voltage has been supplied to the power input module.

If fuses burn out repeatedly call Duniway Stockroom. If the digital display consistently shows -"1", it may be that one of the internal power supply protection devices has removed power to the Diaphragm Gauge. You may check this by measuring the voltage at the connector or cable for the unaffected gauge. Since power for both gauges use the same protection device, either connector will show the power supply voltages. Normal range for the voltages are 14.5 to 15.5 volts for both +15 volts and -15 volts. +15 may be measured on the red wire; -15 is on the green wire; power return is on the black wire. If the power supply protection has shut the power off, you will typically measure less than 4 volts on the affected supply.

If you verify that either power supply is shut off, remove power from the Diaphragm Gauge for a few minutes to allow the protection device to reset itself. The protection device does not need to be replaced; it is a reusable thermal fuse.

You may wish to determine the cause for the loss of power supply voltage before applying power again. The 809 will protect itself if it finds excessive power draw again.

Return Procedure

If you need to return the gauge controller to Terranova for service:

- Contact Duniway Stockroom to get a **RMA** (Return Material Authorization) number.
- Then pack the instrument securely.
- Use the original packaging if it is available.
- If the Terranova 809 was shipped with a cable and/or Diaphragm Gauge sensor, diagnosis and repair will be more efficient if all components are returned together.
If this is not convenient, please consult with your Duniway Stockroom Customer Service Representative
- If you do not have appropriate packing materials, a commercial packing and shipping firm can provide them.
- Be sure to mark the **RMA** number on the outside of the package.

VII Warranty

Terranova products of Duniway Stockroom Corp. are warranted to be free of defects in material and workmanship for a period of one year from the date of shipment. At our option, we will repair or replace products which prove to be defective during the warranty period. Liability under this warranty is limited to repair or replacement of the defective items. Shipping damage is excluded from the scope of this warranty. Gauge tubes of all types are excluded from this warranty.

Terranova products are warranted not to fail to execute programming instructions due to defects in materials and workmanship. If Duniway Stockroom receives notice of such defects during the warranty period, Duniway Stockroom will repair or replace firmware that does not execute its programming instruction due to such defects. Duniway Stockroom does not warrant that the operation of the firmware or hardware will be uninterrupted or error-free.

If this product is returned to Duniway Stockroom for warranty service, Buyer will pre-pay shipping charges and will pay all duties and taxes for products returned to Duniway Stockroom. Duniway Stockroom will pay for return of products to Buyer, except for products returned to a Buyer from a country other than the United States.

LIMITATION OF WARRANTY: *The foregoing warranty does not apply to the defects resulting from:*

- 1. Improper or inadequate maintenance by Buyer;*
- 2. Buyer-supplied interfacing;*
- 3. Unauthorized modification or misuse;*
- 4. Operation outside of the environmental specifications of the product; or*
- 5. Improper site preparation and maintenance.*

THE WARRANTY SET FORTH ABOVE IS EXCLUSIVE AND NO OTHER WARRANTY, WHETHER WRITTEN OR ORAL, IS EXPRESSED OR IMPLIED. DUNIWAY STOCKROOM DISCLAIMS ANY IMPLIED WARRANTIES OF MERCHANTABILITY AND FITNESS FOR A PARTICULAR PURPOSE.

EXCLUSIVE REMEDIES: *The remedies provided herein are Buyer's sole and exclusive remedies. In no event will Duniway Stockroom be liable for direct, indirect, special, incidental, or consequential damages, including loss of profits, whether based on contract, tort, or any other legal theory.*

rev120313sr