

Ion Pumps - Operation and Applications



Ion Pumps - Outline

- Where they fit in the vacuum pumping realm
- Basic principles of operation
- Genealogy of ion pump configurations
- Parameters 'BVD'
- Pumping mechanisms for common gases
- Typical operating cycle
- Common applications
- Applications in microscopy
- Problems and troubleshooting

Vacuum Pumps Types & Ranges

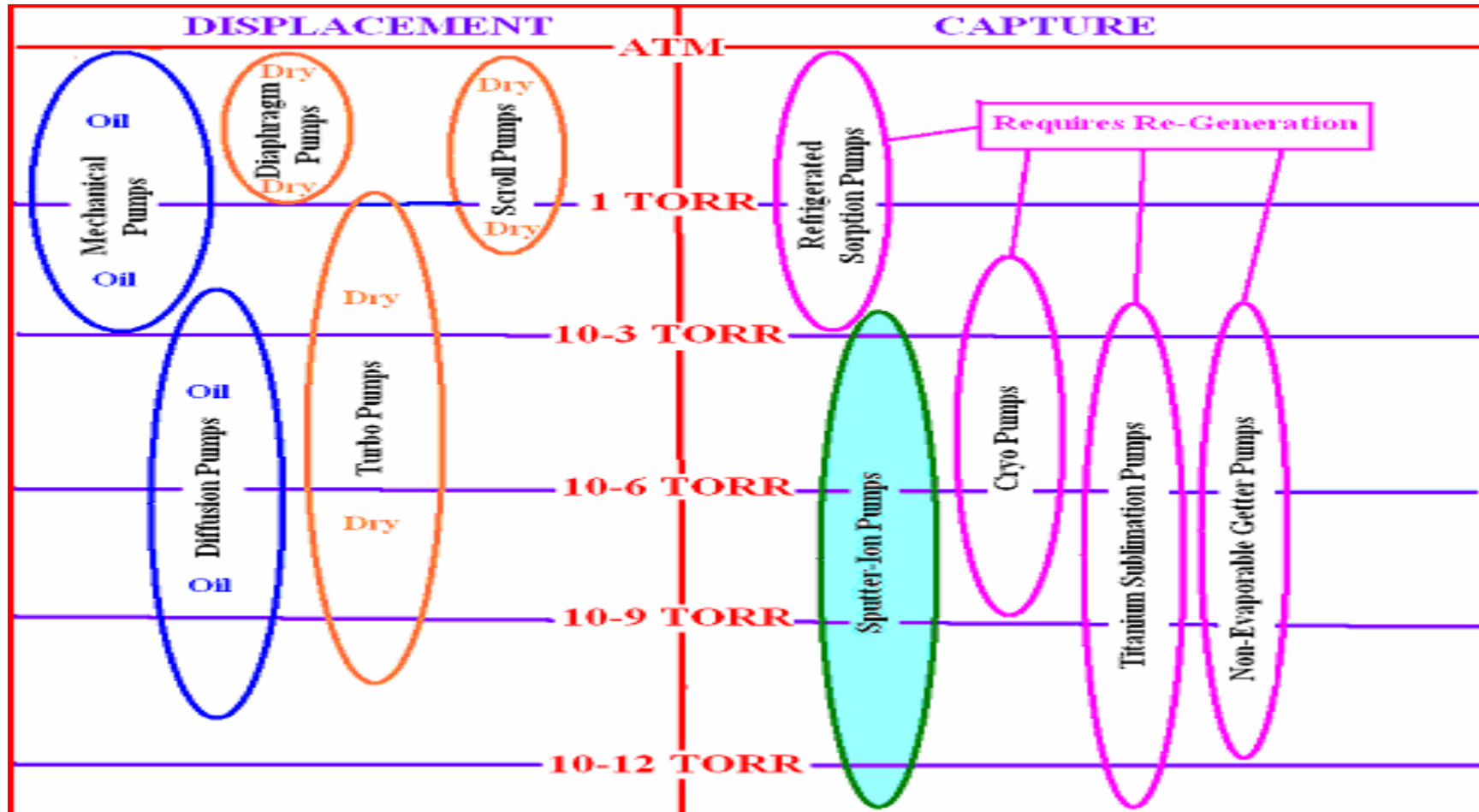

Ion Pumps

Main Characteristics

- “Capture” Pumping; No Backing Required
- Contamination-Free
- Vibration-Free
- Ion Current Provides Pressure Indication
- Long Life at HV and UHV
- Low Maintenance
- Simple Operation

Ion Pump Principle Penning Discharge

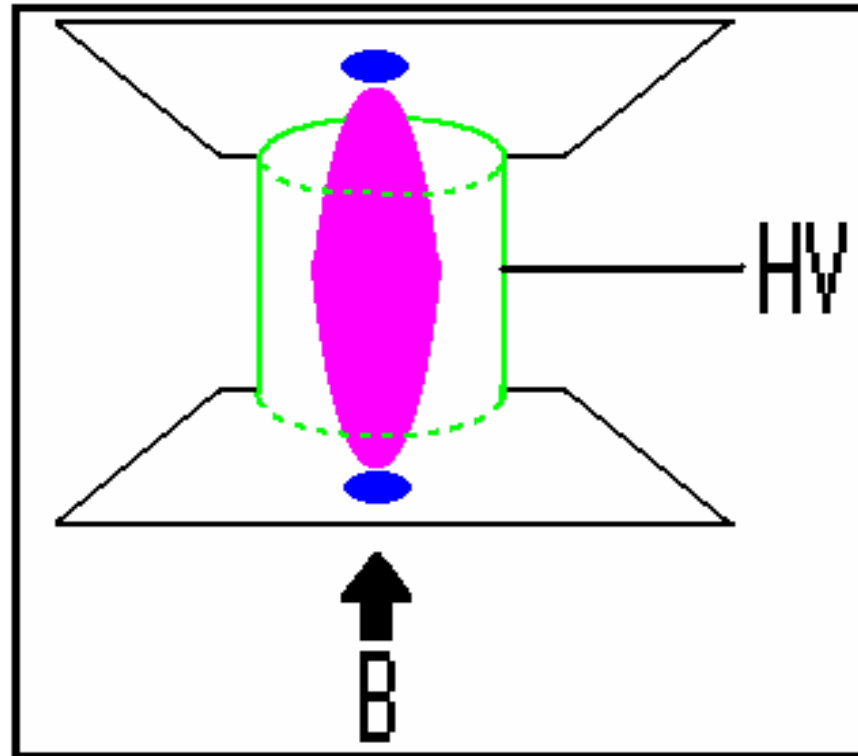

Ion Pump Current Provides Pressure Indication

- Ion Current is Proportional to Pressure
- Wide Range Pressure Indicator
 - UHV – Limited by Field Emission Current
 - High Pressure ($>10^{-4}$ Torr) Power Limited
- Approximate Relationship:
 - $I/P = 10 \times S$, for example:
 - $I/P = 1000$ amps/torr for typical 100 l/s Pump
 - See Table on Next Page

Current vs Pressure

Typical 100 L/S Ion Pump

Pressure - Torr	Ion Current - Amps	Comment
1×10^{-3}	3×10^{-1}	Power Supply Limited
1×10^{-4}	1×10^{-1}	I = 1000 P
1×10^{-5}	1×10^{-2}	I = 1000 P
1×10^{-6}	1×10^{-3}	I = 1000 P
1×10^{-7}	1×10^{-4}	I = 1000 P
1×10^{-8}	1×10^{-5}	I = 1000 P
1×10^{-9}	1×10^{-6}	I = 1000 P
1×10^{-10}	5×10^{-7}	Field Emission Limited

Current vs. Pressure 100 L/S Ion Pump

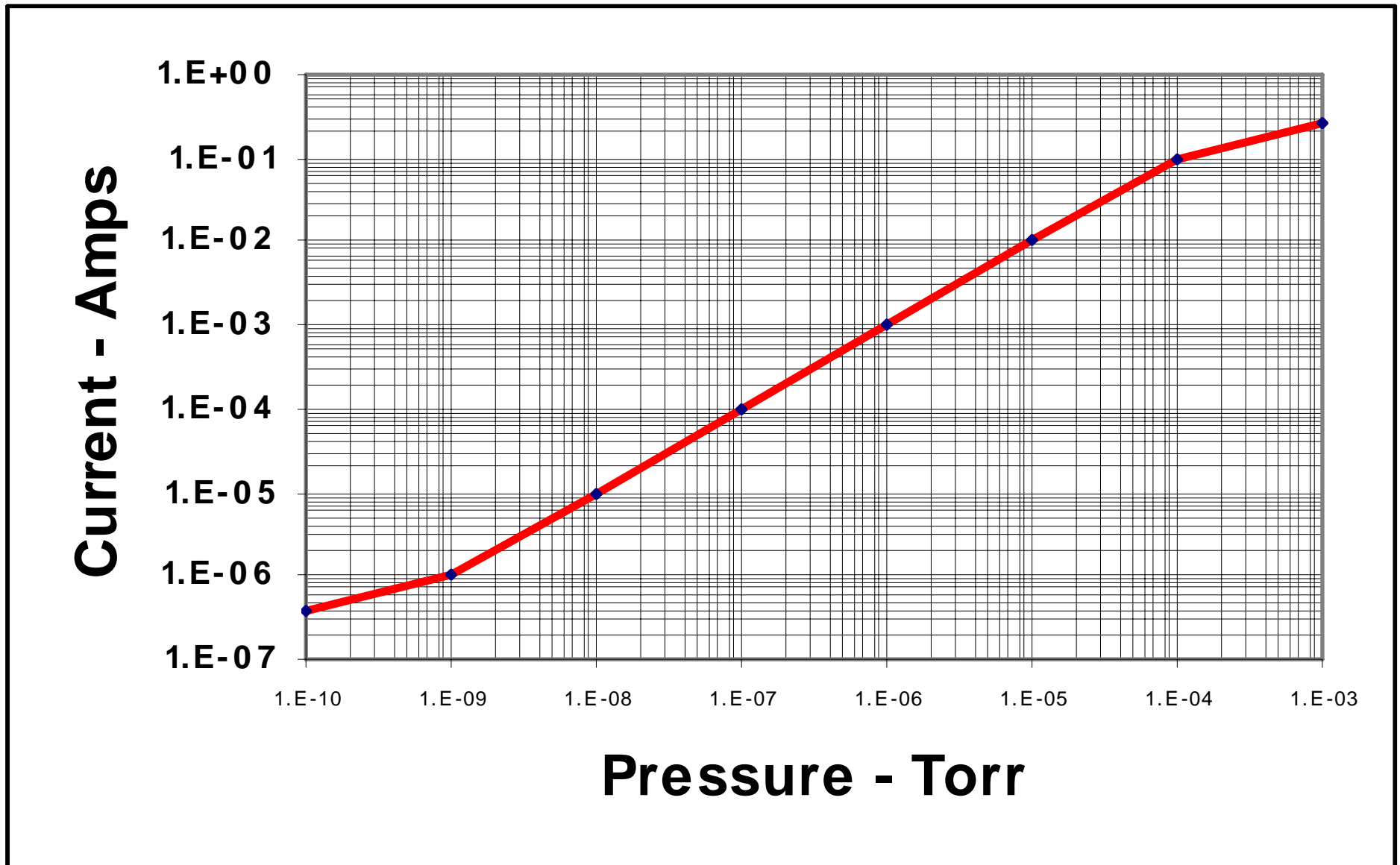

Ion Pumps

Element/Cathode Genealogy

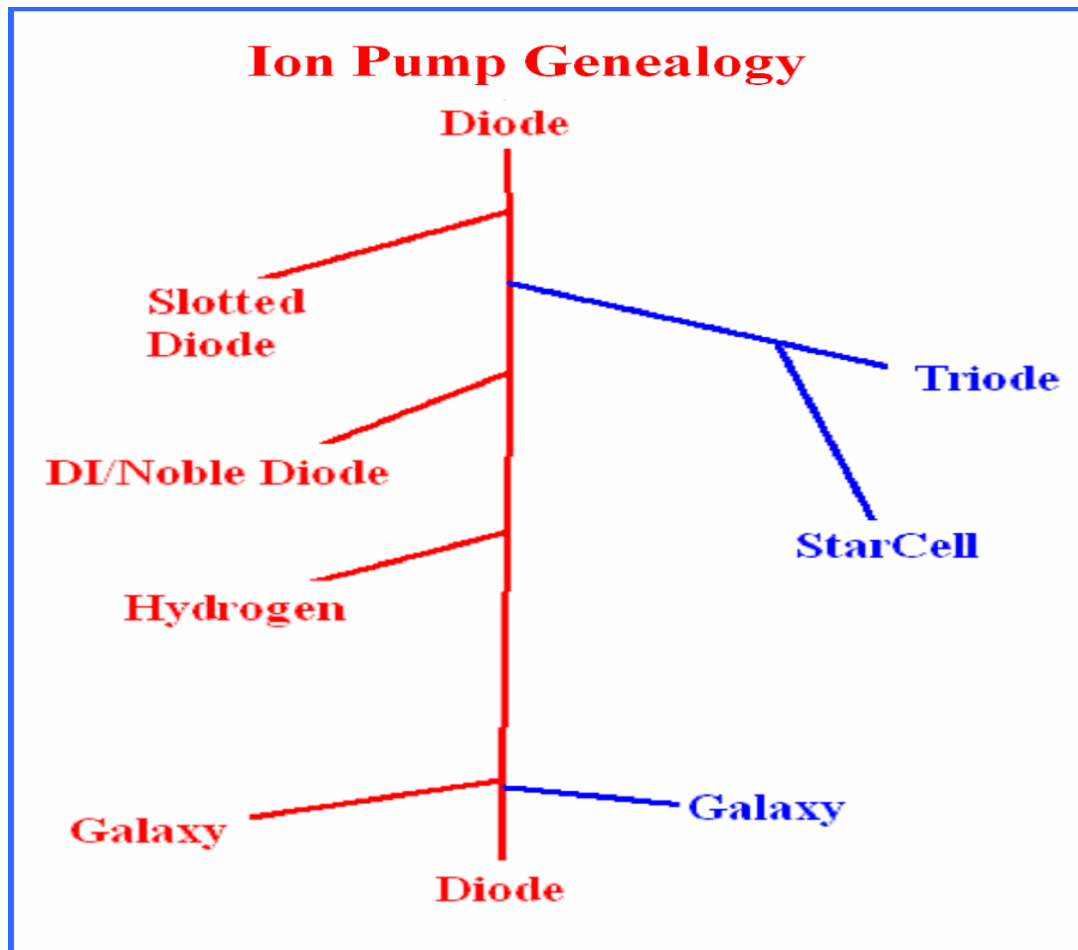

Diode Element

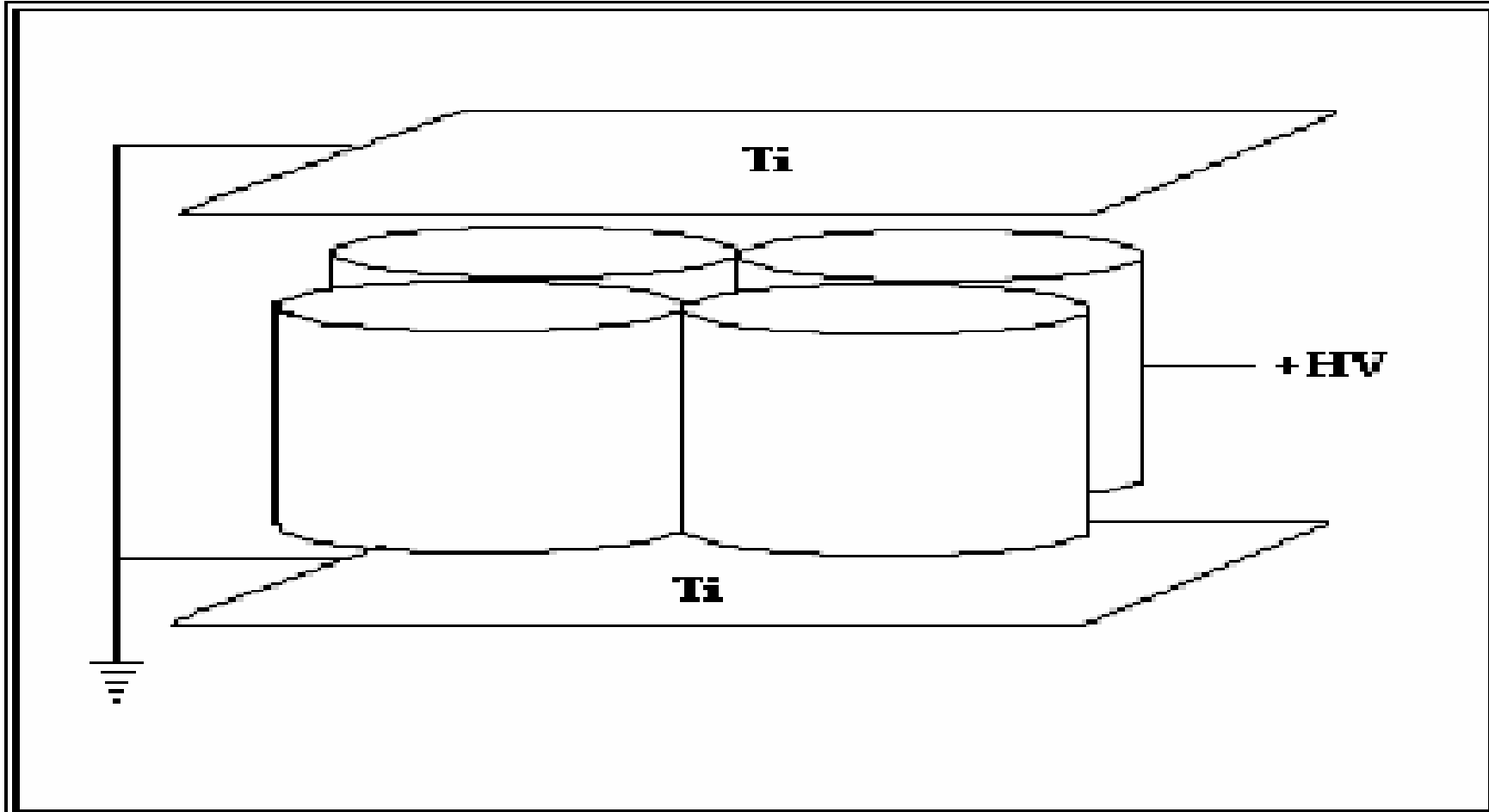

Slotted Diode Element

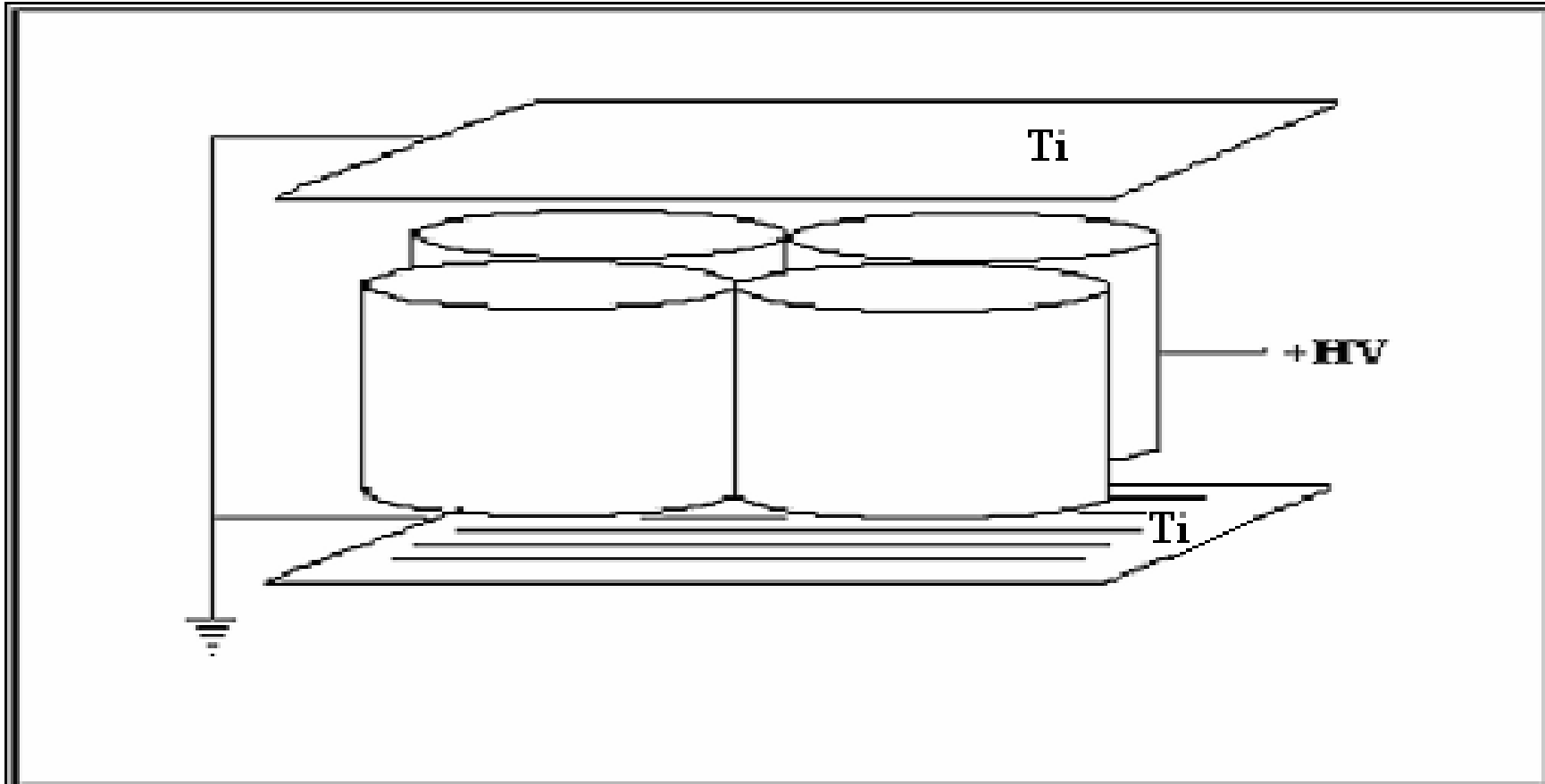

Triode Element

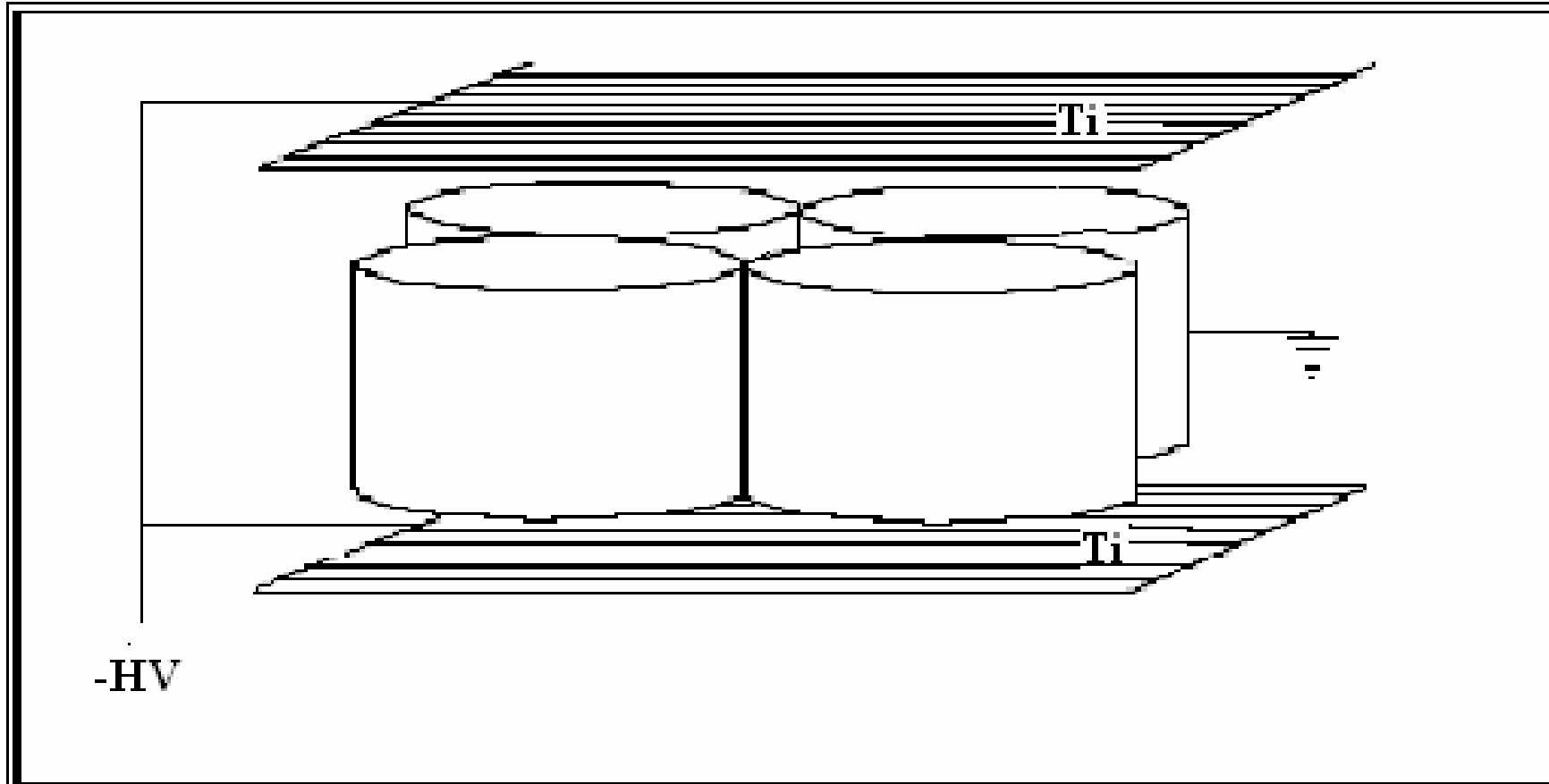

Differential/DI/Noble Diode Element

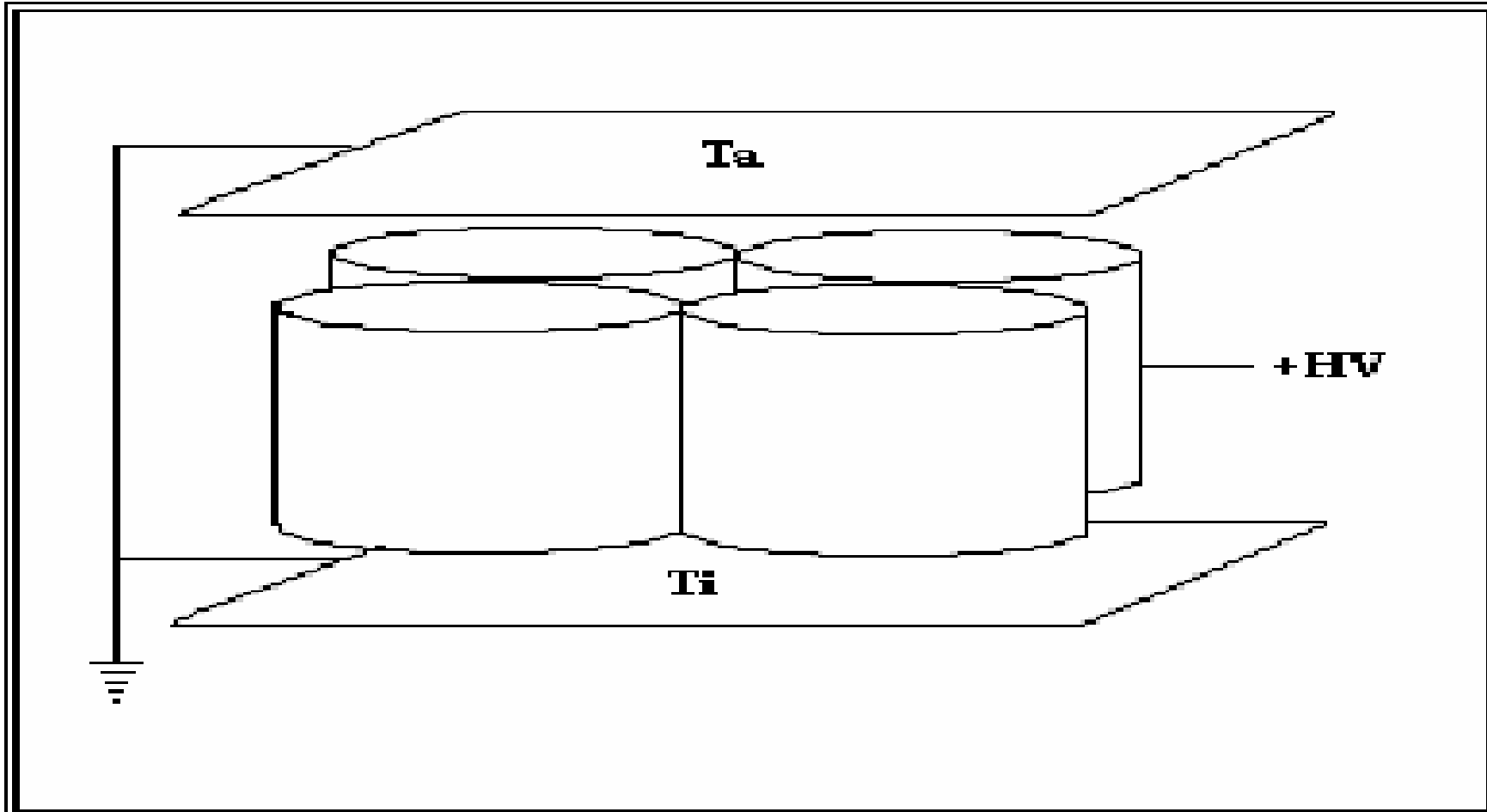

Hydrogen Element

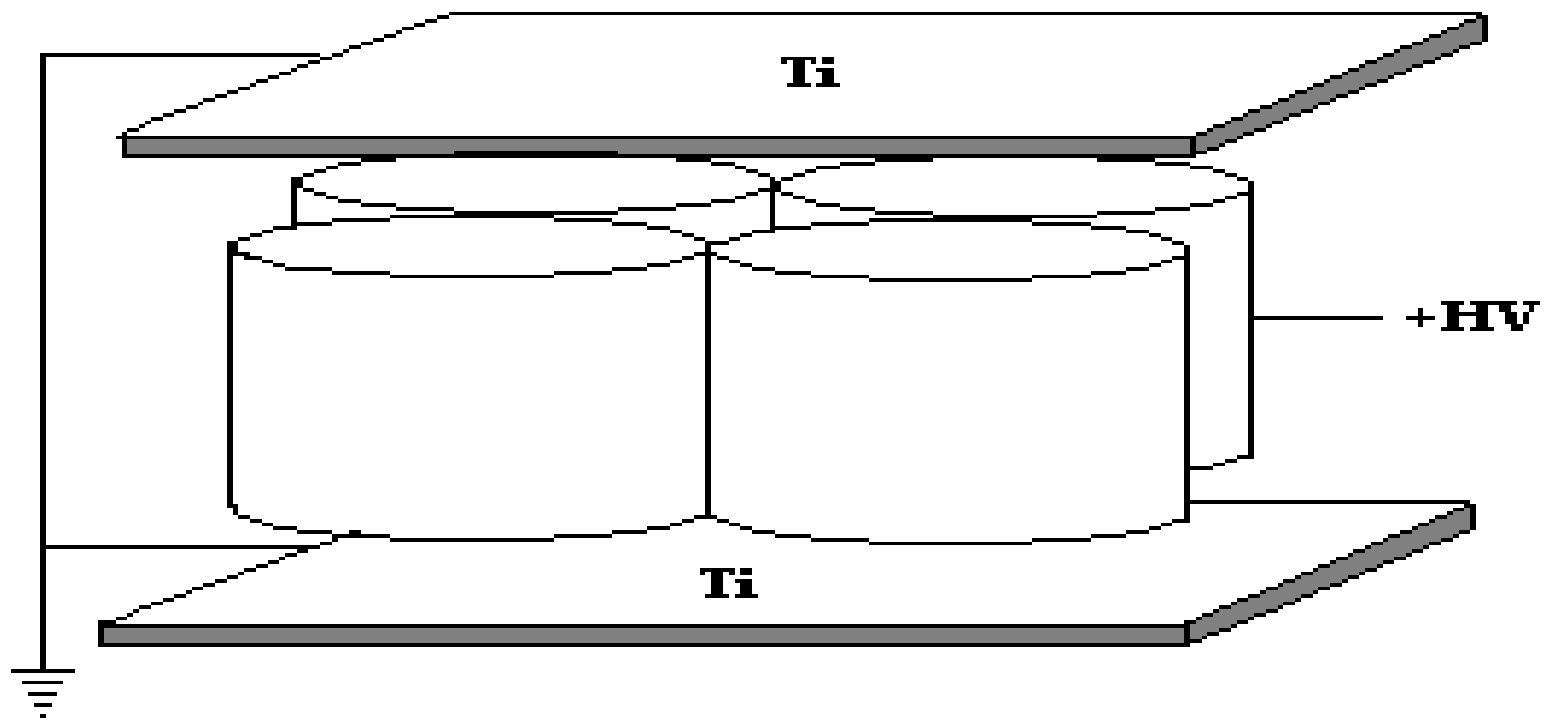

StarCell™ Element

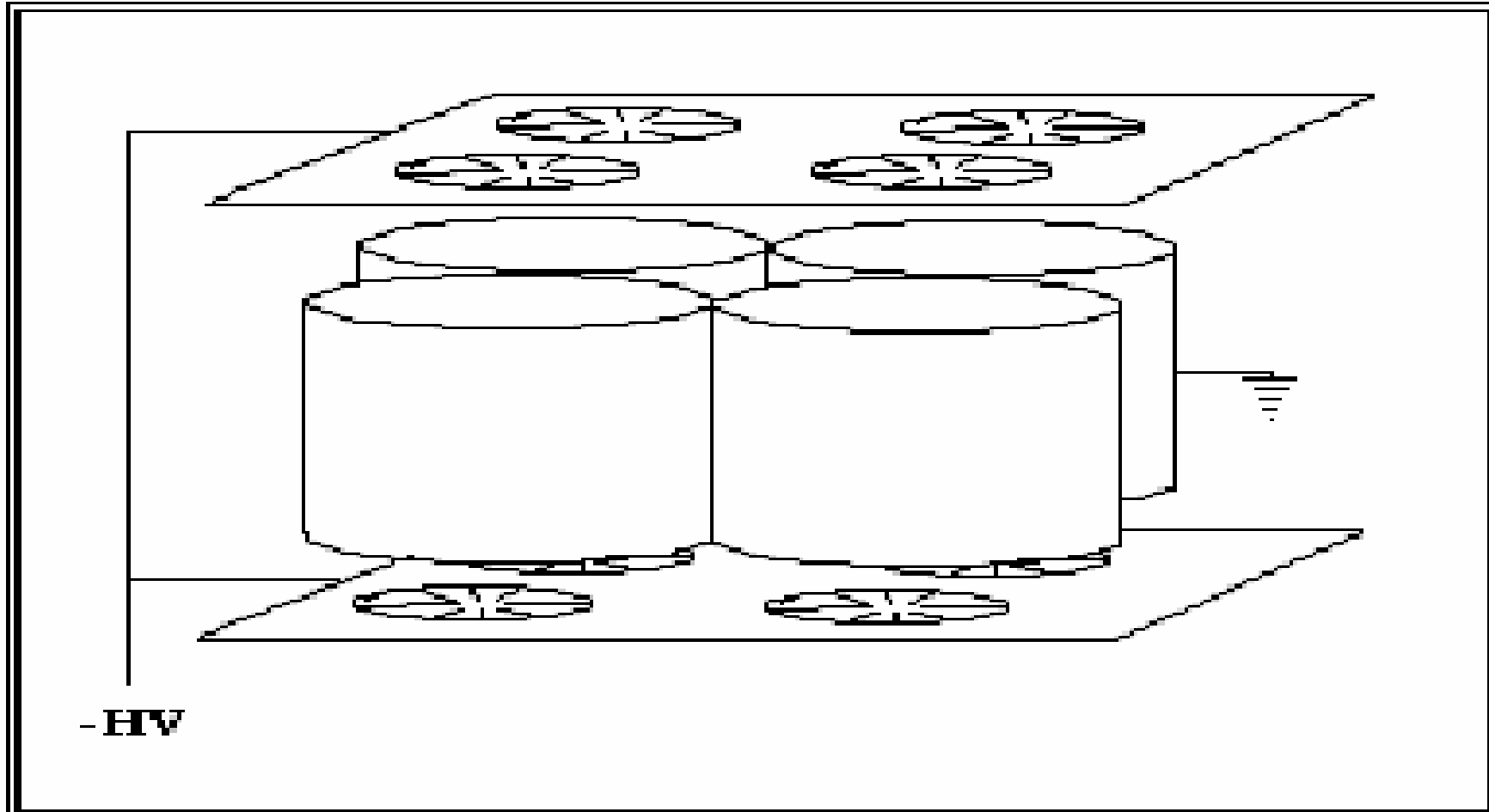

Galaxy™ Diode Element

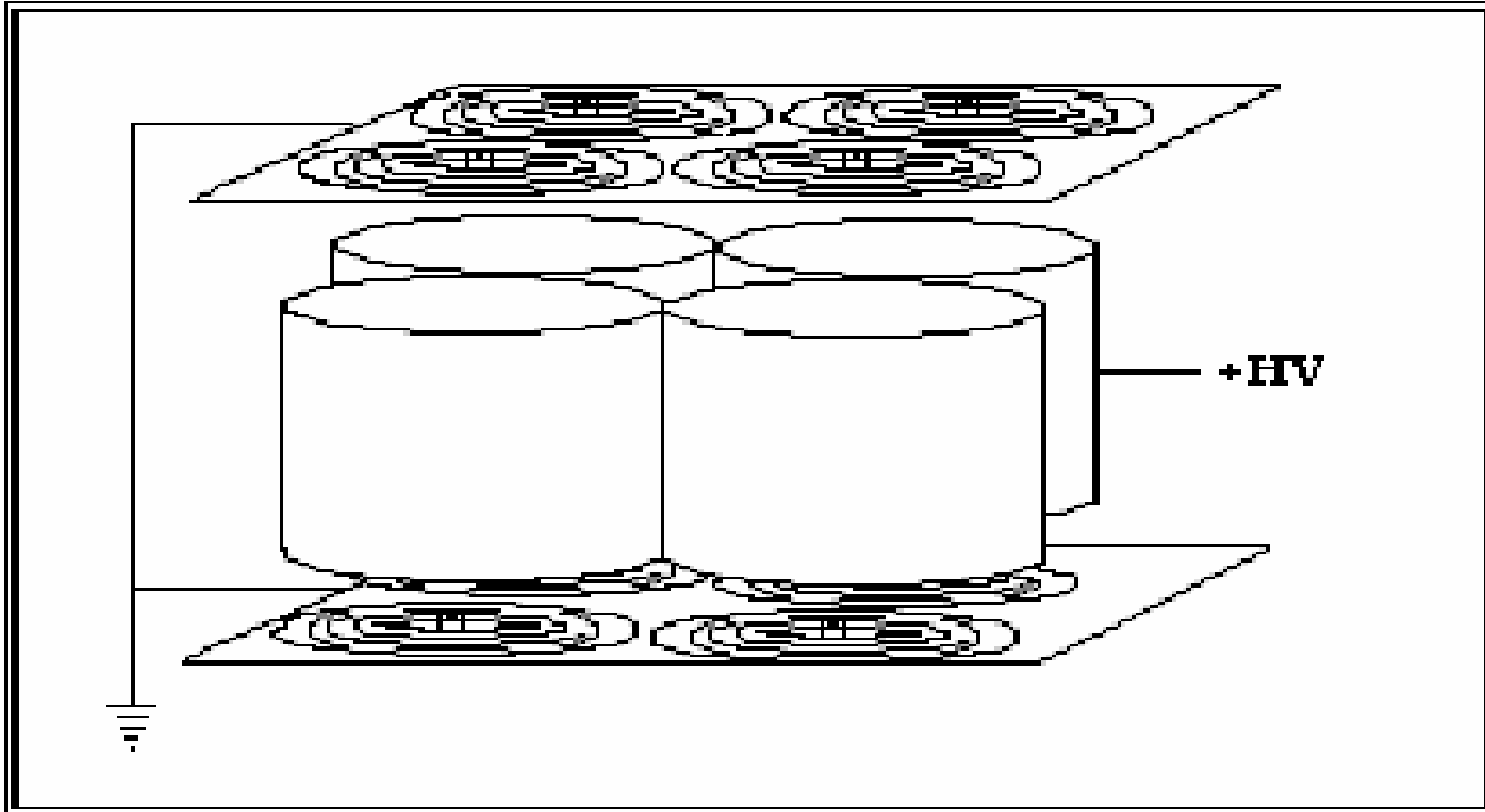

Galaxy™ Triode Element

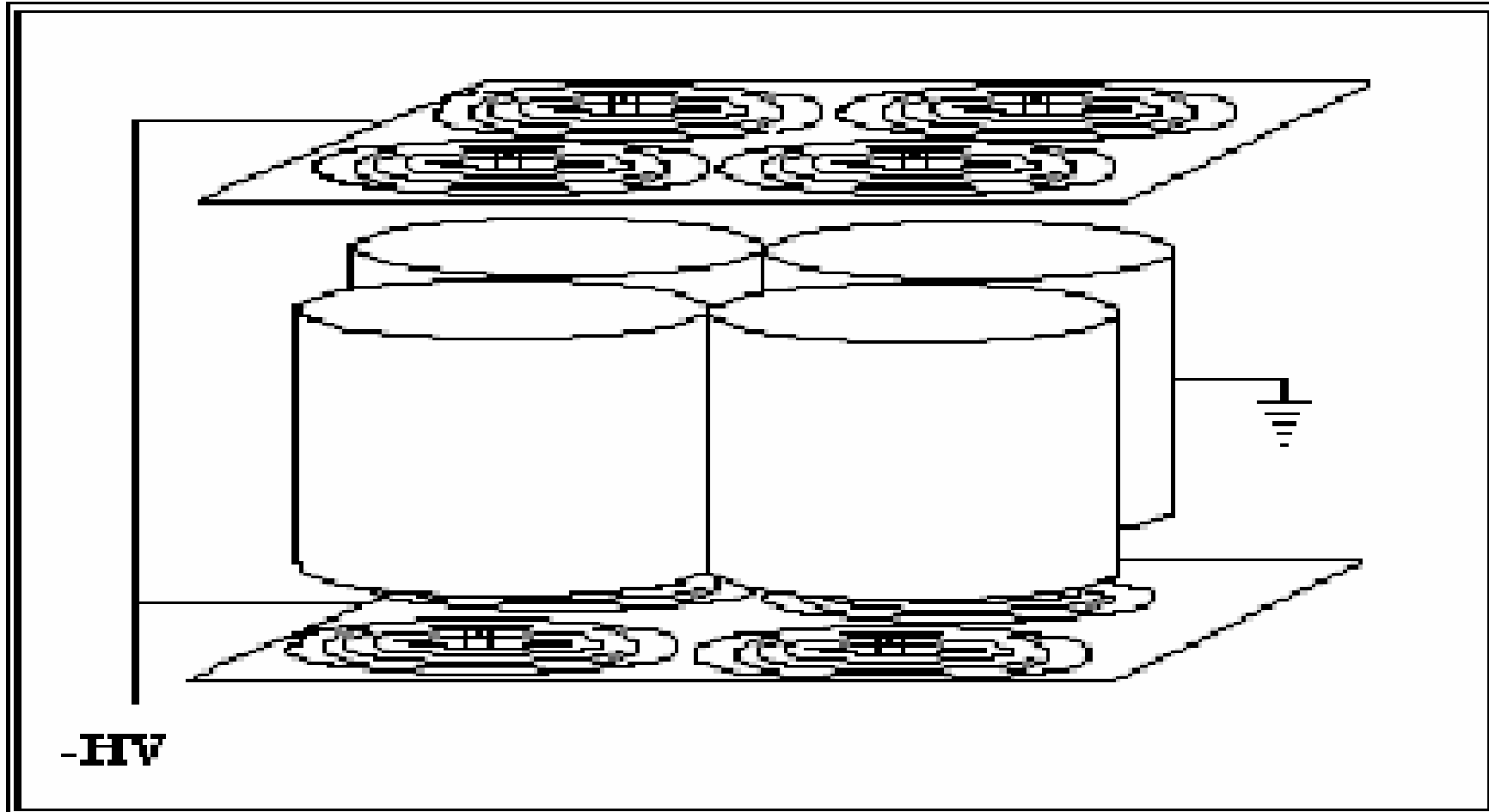

Ion Pump Parameters 'BVD'

- B = Magnetic Field Strength
- V = Operating Voltage
- D = Anode Cell Diameter

B = Magnetic Field

Low Pressure Operation Improves with Higher B
Typical Magnetic Field 1200 to 1500 Gauss

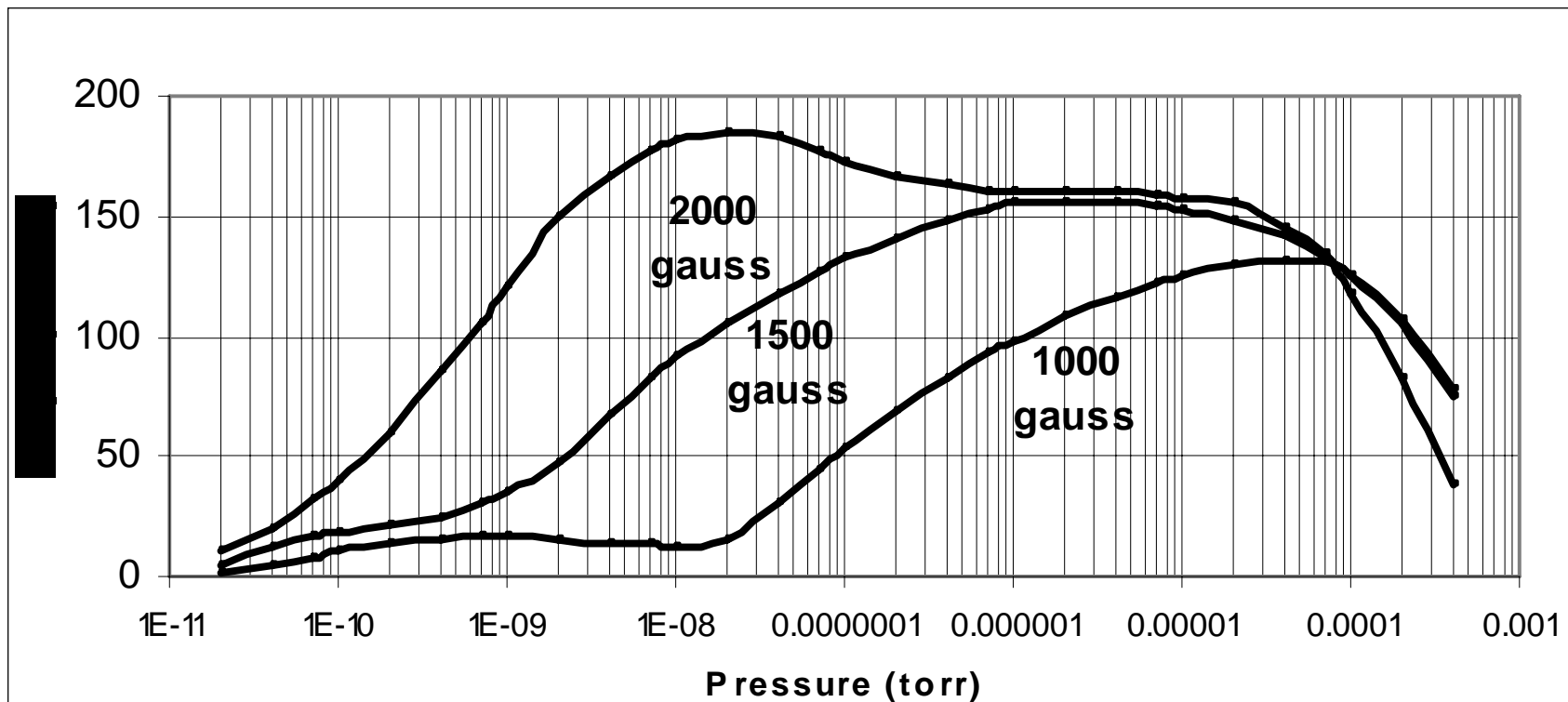
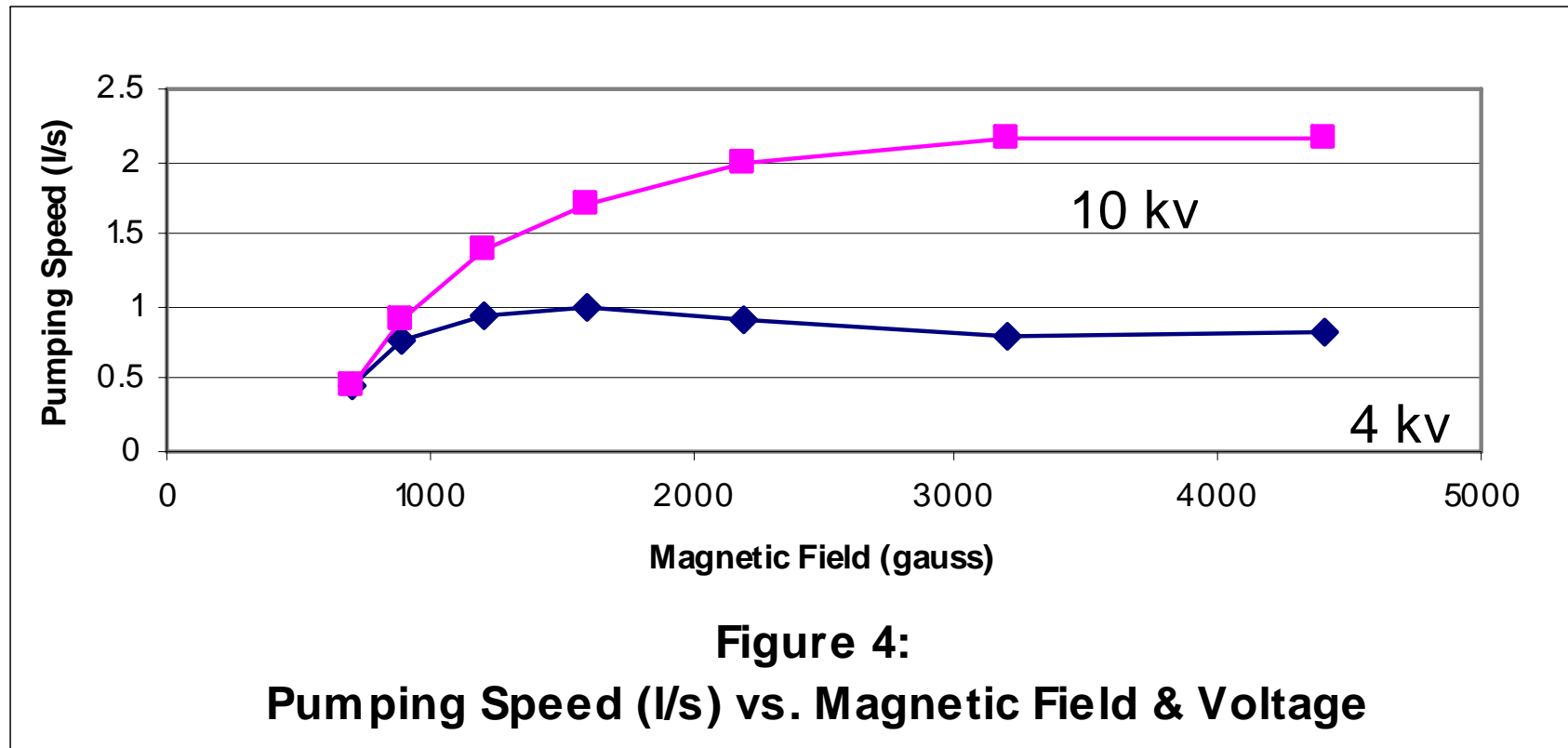

Figure 5: Discharge Intensity vs. Pressure

Three Different Magnetic Fields
(36 Anode Cells, 0.5" Diameter, 3000 Volts)

V = Operating Voltage

Pumping Speed Increases Linearly with Voltage
Typical Operating Voltage 4000 to 7000 Volds DC



D = Anode Cell Diameter

Low Pressure Operation Improves with Larger D
Typical Anode Cell Diameter 0.5 to 1.0 inch

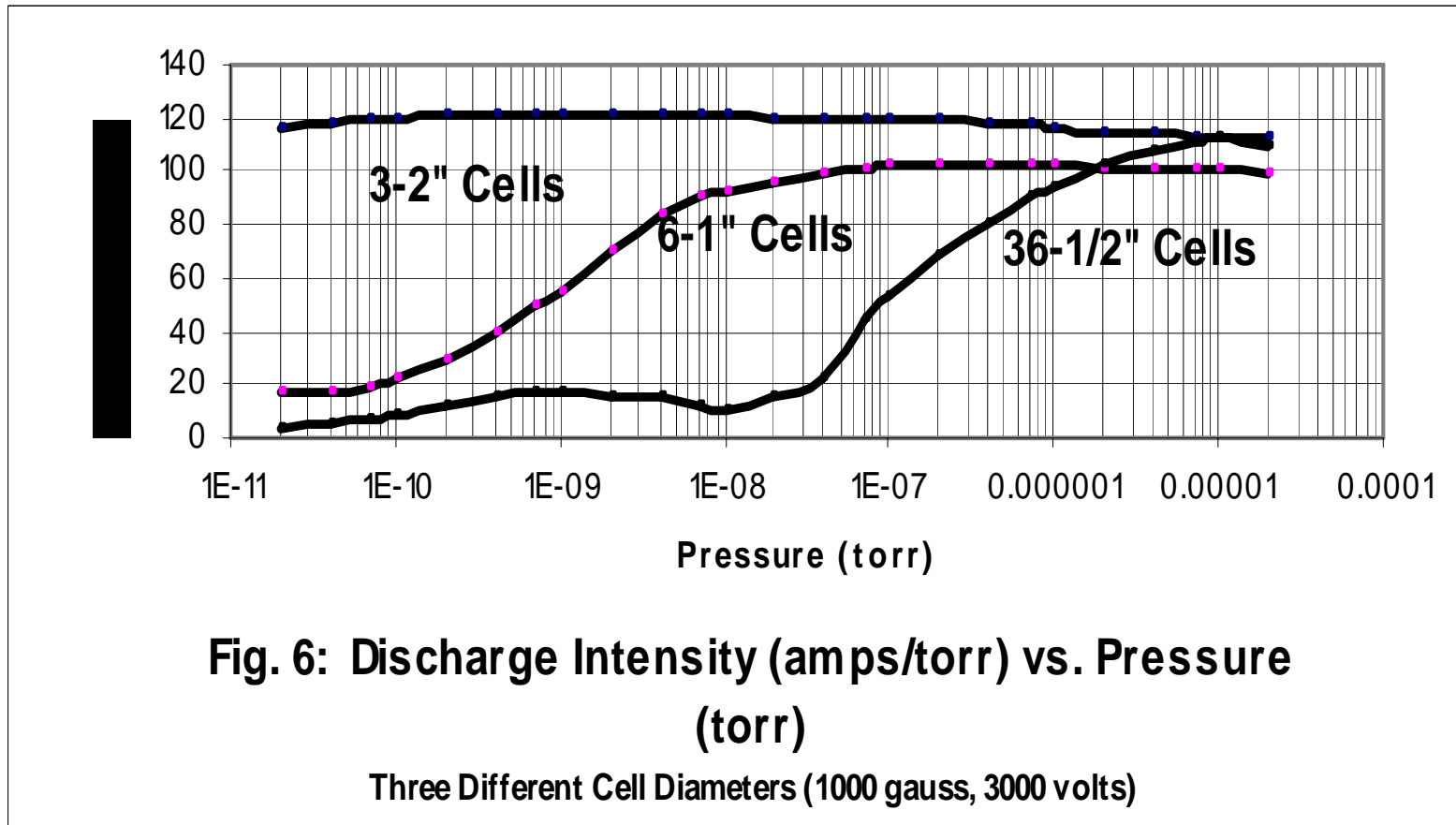

Pumping Mechanisms for Common Gases

- Chemically active:
N, O, H
- Common small molecules:
H₂O, CO, CO₂, CH₄, NH₃, NO
- Noble gases:
Ar, He, Ne, Kr, Xe

Chemically Active Gases



- **Dissociated & Ionized in Discharge**
- **Accelerated to Cathode**
- **Nitrogen and Oxygen**
 - Sputter Titanium Cathode Material**
 - Neutralized**
 - Form stable, chemical combination in regions of sputtered titanium**
- **Hydrogen**
 - Solution/Diffusion into Titanium**
 - Mostly in the Cathodes**

Common Small Molecules

H₂O, CO, CO₂, CH₄, NH₃, NO

- **Dissociated & Ionized in Discharge**
- **Accelerated to Cathode**
- **Active Ions – O, N, H**
 - Same pumping mechanism as active gases
- **Carbon**
 - Accelerated to cathode, neutralized
 - Deposited as free carbon

Noble Gases

He, Ne, Ar, Kr, Xe

- **Ionized in Discharge**
- **Accelerated to Cathode**
- **Sputter/Neutralized**
- **Sputtering rate goes up with mass**
- **Pumped stably in areas of net buildup of sputtered material (cathode, pump walls, anode)**
- **Heavier noble gases require proper element configuration for stable pumping**
(Triode, DI/Noble, Starcell™, Galaxy™)
- **Helium diffuses into titanium**

Argon Instability

Period Shorter at Higher Leak Rates

$P_{\max} \sim 2 \times 10^{-4}$ Torr (Discharge Mode Shift)

Argon Displaced into Stably Pumped Areas During Mode Shift

Slow Rise/Rapid Decline Characteristic Wave Shape

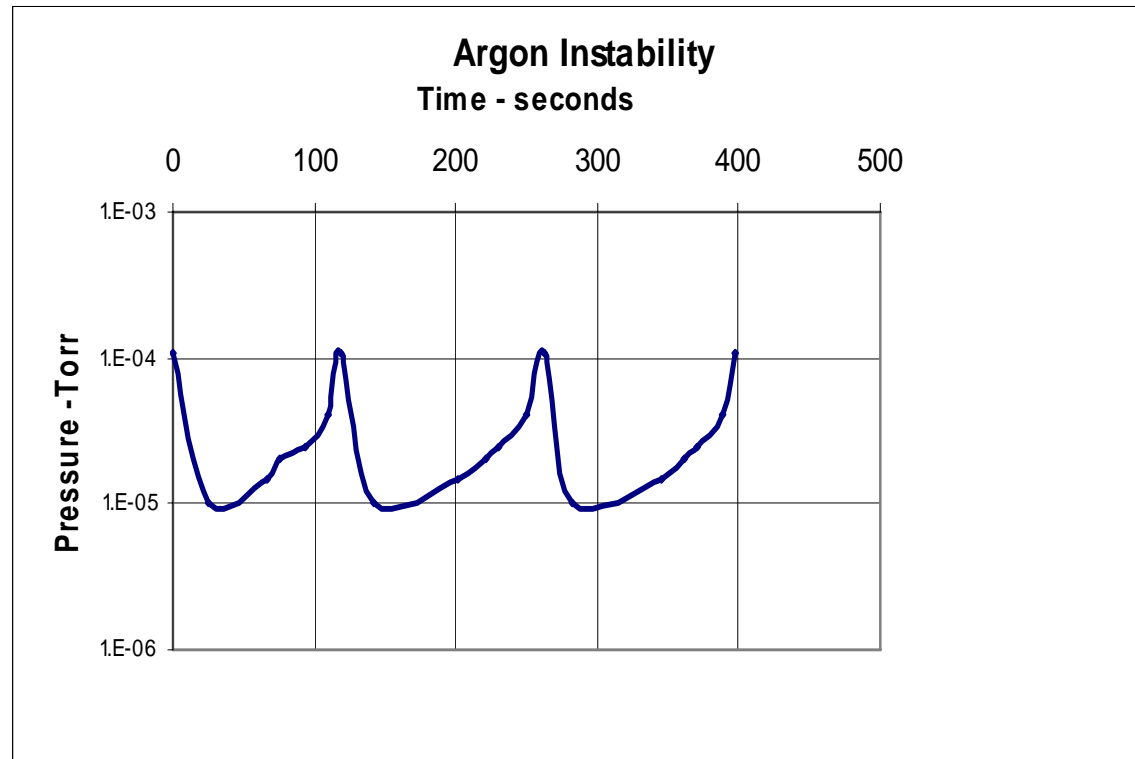

Ion Pumps

Typical Operating Cycle

- **Rough Pump with Clean Technology**
 - Turbo, Trapped Mechanical, Sorption
 - Rough to Pressure Below 10^{-3} Torr
 - Lower Pressure Saves Time, Extends Life
- **Turn on Ion Pump Control Unit High Voltage**
- **Cycle Power if Necessary to Avoid Overheating**
- **Valve Off Roughing Pump**
- **Walk Away**

Ion Pumps

Common Applications

- Electron Microscopes
- Accelerators
- Microwave Tubes
- X-ray Tubes
- Medical Equipment
- Coating Equipment
- Materials Research
- Mass Spectrometers

Ion Pumps

Applications in Microscopy

- Source
- Column
- Sample Chamber
- Sample Metallizing/Coating
- Sample Storage

Ion Pumps

Problems and Troubleshooting

- Initial Set-Up and Operation
- Field emission leakage
- ‘Noisy’
- Over-Heats
- Hard to Start – High Pressure
- Hard to Start – Low Pressure
- “Sluggish”, Low Pumping Speed
- Lifetime

Initial Set-Up and Operation

- Leak-Tight Connection
- Proper Conductance: $> 5X$ Pump Speed
- Correct Magnet Strength/Orientation
- Visible Grounding Wire
- Good High Voltage Connection
 - Pump HV Feedthrough
 - HV Connector – Pump End
 - HV Connector – Controller End

Field Emission Leakage

- Buildup of Sharp-Pointed Deposits
- Field Emission Current from Points
- Masks Ion Current at Low Pressures
- Doesn't Influence Pumping Speed
- Can Be Removed by "Hi-Potting"

'Noisy'

- Long-Term Operation Builds up Sputtered Deposits
- Deposits Can 'Flake Off'
- Occurs Especially with Vibration, Shock
- Generates Current/Pressure Spikes as Flakes Fall into Discharge
- When Such Noise becomes a Problem, Pump Needs Cleaning/Rebuilding

Over-Heats

- Occurs at Higher Pressure, ie $>10^{-5}$ Torr
- With Properly Matched Control Unit, Damage Will Not Occur
- Caused by Excessive Gas Load
- Reduce Gas Load or Add Auxiliary Pump
 - Titanium Sublimation, Cryo, Turbo, NEG
- May Require Re-Roughing if Excessive

Hard to Start – High Pressure

- May be Caused by Inadequate Roughing
- Badly-Matched Control Unit with Excessive Power Could Cause Over-Heating
- Older Pump May Have Adsorbed Gases on High Surface Area Deposits or Dissolved Gases (H, He) in Cathodes
- Improve Roughing or Clean/Rebuild

Hard to Start – Low Pressure

- Most Likely to Occur at UHV
- Discharge Needs an ‘Event’ to Initiate
- ‘Events’ Less Likely at Low Pressures
- Smaller Pumps Most Susceptible
- A Gentle Tap May Help
- Injected Electrons or UV Sometimes Used

“Sluggish”, Low Pumping Speed

- Older Pumps May Release Gas from Deposited High Surface Area
- Baking Pump During Start May Help
- Clean/Rebuild makes Pump Like New
- System Design May Limit Conductance to Pump, Limiting Speed
- Larger Diameter, Shorter Attachment Will Help

Ion Pumps Lifetime

- Normal Lifetime is 30,000 – 40,000 Hours at a Pressure of 1×10^{-6} Torr
- Heavy Noble Gases May Cut Life
- Lifetime is Inversely Proportional to Pressure:
 - 1/10X at 1×10^{-5} Torr
 - 10X at 1×10^{-7} Torr
 - 100X at 1×10^{-8} Torr
 - ETC.

Ion Pumps - Conclusion

- **When applied properly, ion pumps are an excellent, reliable solution for HV and UHV**



Contact Information

- Duniway Stockroom Corp.
1305 Space Park Way
Mountain View, CA 94043
Phone: 650-969-8811
FAX: 650-965-0764

www.duniway.com