

## Instruction Manual

# Terranova Model 751

## Ion Pump Power Supply

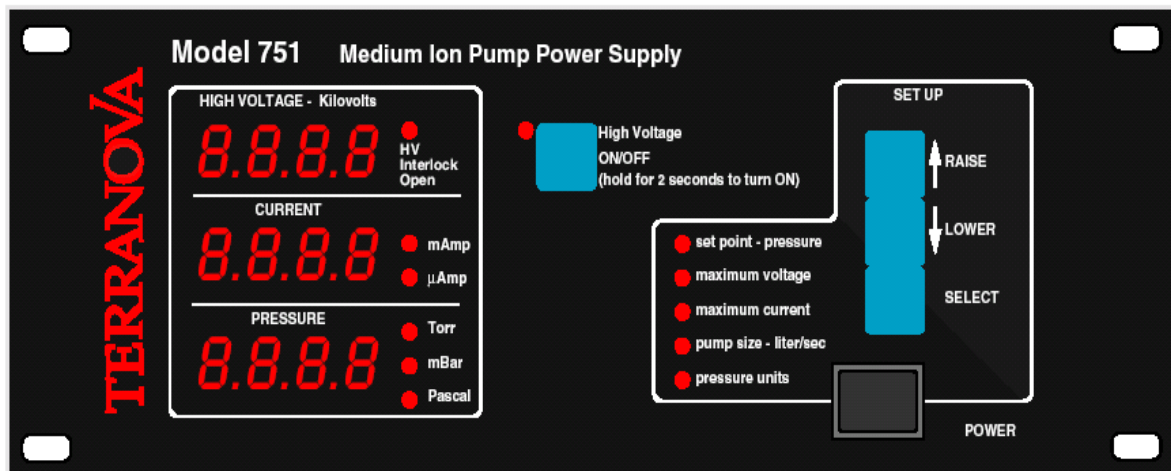

Copyright © 2003 by Duniway Stockroom Corp.

rev053105sr

# Table of Contents

---

<b>I Technical Specifications</b>	<b>page 4</b>
A. Description	
B. Specifications	
C. Connector Pin Listing	
<b>II Installation</b>	<b>page 9</b>
A. General Considerations	
B. Front Panel Description and Preliminary Set Up	
C. Initial Set Up & Set Point Operation	
D. Safety Considerations	
E. Rear Panel Description	
F. Safety Interlock Operation	
G. Connection to the Ion Pump	
<b>III Operation</b>	<b>page 19</b>
A. Start Mode Operation	
B. Normal Mode Operation	
C. Communications Functions: RS-232, 422 ad 485 Commands	
D. Power/Voltage Characteristics	
<b>IV Maintenance</b>	<b>page 25</b>
A. 751 Block Diagram	
B. Verification of Operation	
C. Diagnosing Ion-Pumped System Conditions	
D. Trouble Shooting	
E. High Voltage Output Polarity Change Procedure	
F. Analog Output Range Settings	
G. Internal DIP Switch Settings	
H. Fuses	
I. High Voltage Cables	
<b>V Warranty &amp; CE Declaration</b>	<b>page 37</b>

## List of Figures

<b>Figure 1:</b>	<b>Serial Interface Connector Pins</b>	<b>page 7</b>
<b>Figure 2</b>	<b>Serial I/O Connector-Rear Panel</b>	<b>page 7</b>
<b>Figure 3</b>	<b>Miscellaneous I/O Connector Pins</b>	<b>page 8</b>
<b>Figure 4</b>	<b>Miscellaneous I/O Connector</b>	<b>page 8</b>
<b>Figure 5</b>	<b>Ion Pump Operating Pressures</b>	<b>page 9</b>
<b>Figure 6</b>	<b>Front Panel</b>	<b>page 10</b>
<b>Figure 7</b>	<b>Rear Panel</b>	<b>page 15</b>
<b>Figure 8</b>	<b>Ground-Sense Conditions</b>	<b>page 17</b>
<b>Figure 9</b>	<b>Serial Interface Format</b>	<b>page 22</b>
<b>Figure 10</b>	<b>Serial Interface Parameter Set</b>	<b>page 23</b>
<b>Figure 11</b>	<b>Power vs. Current Curve</b>	<b>page 23</b>
<b>Figure 12</b>	<b>Voltage vs. Current Curve</b>	<b>page 24</b>
<b>Figure 13</b>	<b>Block Diagram</b>	<b>page 25</b>
<b>Figure 14</b>	<b>Top View, Cover Removed</b>	<b>page 33</b>
<b>Figure 15</b>	<b>DIP Switch - S1 - Settings</b>	<b>page 35</b>
<b>Figure 16</b>	<b>DIP Switch S2 Settings</b>	<b>page 35</b>

## I Technical Specifications

### A. Description

The Terranova Model 751 Ion Pump Control Unit is designed to supply operating power to a sputter ion pumps and to display the voltage, current and pressure. It is designed to start and operate pumps of 60 l/s and smaller and to operate larger pumps of any size at lower pressures.

The Terranova Model 751 is a programmable, microprocessor controlled unit, which gives it great versatility in operation, display, control and data communication. Some major features include:

- Programmable High Voltage Output
- Programmable Maximum Current
- Programmable Pump Size for Pressure Display
- Choice of Pressure Units
- Programmable Process Control Set Point Relay
- Display for voltage, current and pressure
- RS 232, 422, 485 Serial I/O for Data Collection and Computer Control
- Analog Outputs for Monitoring Voltage and Current
- Ground Sensing Circuit for Operator Safety
- Power Interlock Micro-Switch on Top Cover
- CE, UL, CSA Conformance for EMI, EMC and Safety

## B. Specifications

### 1. Electrical Specifications

#### INPUT PARAMETERS

Voltage	Universal: 100-250 Volts, 50/60 Hz or DC.
Current	1 Amp maximum in START mode (115VAC).

#### OUTPUT PARAMETERS

Open Circuit Voltage	Operator Set +/-3500 to +/- 7500 VDC (Units shipped with + high voltage polarity unless otherwise specified. Instructions for switching polarity are in Section IV)
Short Circuit Current	Operator Set 100 milliamps maximum
Overload Protection	Fuse for line power. Power automatically adjusted for pump starting. Automatic Shutdown for Shorted Output
Display	LED Displays 3 Digits plus Sign (+/-) X.XX - kilovolts 3 Digits Current - milliamp and microamp autoranging 2 Digits plus Exponent for Pressure
Pressure Units	Operator Set: Torr, mbar, Pascal
Set Point Relay	Rated at 240 VAC, 2 Amps

#### ANALOG OUPUTS

Voltage	0 - 10 volts; 1 volt per 1000 volts
Current	0 - 10 volts; User Selectable 200 microamps per volt to 2000 microamps 2 milliamps per volt to 20 milliamps (default)

#### RS-232 INPUT/OUTPUT

Pressure, Current, Set-up	9600 baud, 8-N-1
---------------------------	------------------

## 2. Physical Specifications

### CONNECTORS/CABLES

Line Power	6.7 foot (2 meter) length Belden Type 17250 or equivalent NEMA 5-15P grounding plug PH-290B
High Voltage Output	Options: One or Two - Kings 10 KV Type Connector One or Two - Fischer Type Connector For High Voltage Cables, See Accessory List in Section IV
Serial I/O	9-Pin D-sub type Connector, Female Pins
Miscellaneous I/O	15-Pin D-sub type Connector, Female Pins
Ground Sense	Isolated 8/32 Threaded Stud

### DIMENSIONS

Panel	9.5 in (24.1 cm) W x 3.5 in (9.0 cm) H
Cabinet Depth	16 in (40.6 cm) deep (Allow 4 in (10.2 cm) extra for cable clearance)

### WEIGHT

Installed Weight	6 lb (2.7 kg)
Shipping Weight	10 lb (4.5kg)

### OPERATING ENVIRONMENT

Temperature	32°F to 105°F(0°C to 40°C)
Humidity	0 - 80% Relative Humidity, Non- condensing
Altitude	Sea Level to 10,000 feet (3100 meters)

---

### C. Connector Pin Configuration

#### 1. Serial RS-232 Multi-Drop RS-422/485 Rear Panel, 9-pin D-sub type connector

<u>PIN</u>	<u>RS-232 SIGNAL</u>	<u>RS-422/485 SIGNAL</u>
Pin 1	DCD	---
Pin 2	RxD	+Tx
Pin 3	TxD	+Rx
Pin 4	DTR	---
Pin 5	SIGNAL GROUND	SIGNAL GROUND
Pin 6	DSR	---
Pin 7	RTS	-Rx
Pin 8	CTS	-Tx
Pin 9	RI	---

**Figure 1: Serial Interface Connector Pin Connections**

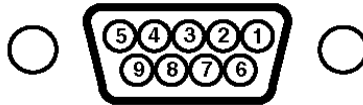

**Figure 2: Serial I/O Connector-Rear Panel**

(The 9 pin D-sub connector on the control unit has female pins, the cable connector must have male pins. An unterminated 9 pin D-sub connector with male pins is included in the accessory kit shipped with the unit. If you have difficulty finding a connector for use with this unit, please call Duniway Stockroom Corp.)

#### **NOTE: INTERNAL JUMPER AND DIP SWITCH SETTINGS:**

Changing from RS-232 configuration to RS-485 configuration requires changes to internal jumpers and internal DIP switches. For RS-232, internal jumper JP1-5 requires a jumper from pin 2 to pin 3. For RS-422 and RS-485, internal jumper JP1-5 requires a jumper from pin 1 to pin 2. See Section IV-D for the DIP switch settings.

Factory default set-up is for RS-232 format 9600 baud, 8-N-1.

**2. Miscellaneous I/O**

**Rear panel, 15-pin D-sub connector**

PIN

SIGNAL

Pin 1	SETPOINT COMMON
Pin 2	SETPOINT NORMALLY CLOSED (NC)
Pin 3	DIGITAL COMMON
Pin 4	ANALOG COMMON
Pin 5	-15 VOLTS, 0.2 A
Pin 6	+15 VOLTS, 0.2 A
Pin 7	+ 5 VOLTS, 0.2 A
Pin 8	HV PULSE CONTROL INPUT, TTL LEVEL
Pin 9	SETPOINT NORMALLY OPEN (NO)
Pin 10	+ 12 VOLTS, 0.2 A
Pin 11	+ 5 VOLTS WHEN SETPOINT 'ON'
Pin 12	CURRENT MONITOR - ANALOG OUT
Pin 13	+ 12 VOLTS WHEN HV 'ON' NEGATIVE
Pin 14	VOLTAGE MONITOR - ANALOG OUT
Pin 15	+ 12 VOLTS WHEN HV 'ON' POSITIVE

**Figure 3: Miscellaneous I/O Connector Pin Connections**

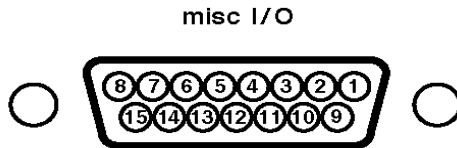

**Figure 4: Miscellaneous I/O Connector - Rear Panel**

(The 15 pin D-sub connector on the control unit has female pins, the cable connector must have male pins. An unterminated 15 pin D-sub connector with male pins is included in the accessory kit shipped with the unit. If you have difficulty finding a connector for use with this unit, please call Duniway Stockroom Corp.)

## II Installation

### A. General Considerations

The Terranova 751 Ion Pump Power Supply is designed for operation, display and control of sputter-ion pumps. Due to the Model 751 output current limitation of 25 mA, it can be used for all functions (starting from the 10<sup>-3</sup> torr range and low pressure operation) only for pumps of approximately 20 liters per second rating and smaller. For larger pumps, the Model 751 can be used only for operation at lower pressure ranges, or for systems roughed with a turbo-pump to appropriately low pressures.

See the table below for recommended maximum pressures of operation.

<u>Pump Rating</u>	<u>Maximum Operating Pressure</u>
400/500 l/s	6 x 10 <sup>-6</sup> Torr
220/270 l/s	2 x 10 <sup>-5</sup> Torr
110/140 l/s	3 x 10 <sup>-5</sup> Torr
60 l/s	1 x 10 <sup>-4</sup> Torr
30 l/s	3 x 10 <sup>-4</sup> Torr
20 l/s	1 x 10 <sup>-3</sup> Torr + Start
8 l/s	1 x 10 <sup>-3</sup> Torr + Start
2 l/s	1 x 10 <sup>-3</sup> Torr + Start
Mini	1 x 10 <sup>-3</sup> Torr + Start

**Figure 5: Operating Pressure Ranges for Various Ion Pump Sizes**

The Terranova 751 Ion Pump Control unit is designed to operate either diode or triode sputter ion pumps. These generic pump types differ in two important ways; namely:

**Diode pumps require positive high voltage. Typical examples would be the Varian-style 8 l/s, 20 l/s, 30 l/s and 60 l/s models or P-E-style 20 l/s, 25 l/s, 40 l/s and 50 l/s. Diode pumps can also be called “Noble Diode”, “Galaxy<sup>tm</sup> Diode” and “Differential Ion”. Factory set-up is for Positive High Voltage unless otherwise specified; for diode style pumps only.**

**Triode pumps require negative high voltage. Typical examples would be the Varian-style 20 l/s, 30 l/s, 45 l/s and 60 l/s models. Triode pumps can also be called “StarCell<sup>R</sup>” and “Galaxy<sup>tm</sup> Triode”.**

**See Section IV for High Voltage Polarity changeover procedure**

Galaxy is a trademark of Duniway Stockroom Corp.; StarCell is a trademark of Varian, Inc.

A typical sputter ion pump is generally very tolerant of a wide range of power supply operating characteristics in the NORMAL mode of operation. This mode exists at pressures less than the critical transition pressure, usually around  $10^{-4}$  torr. This pressure depends upon the design of the pump in relation to such parameters as anode cell geometry and magnetic field. For more information on this topic, please contact your Duniway Stockroom Corporation customer support representative.

In the START mode of operation, sputter ion pumps are generally very intolerant of improper matching of the pump requirements to the electrical characteristics of the power supply.

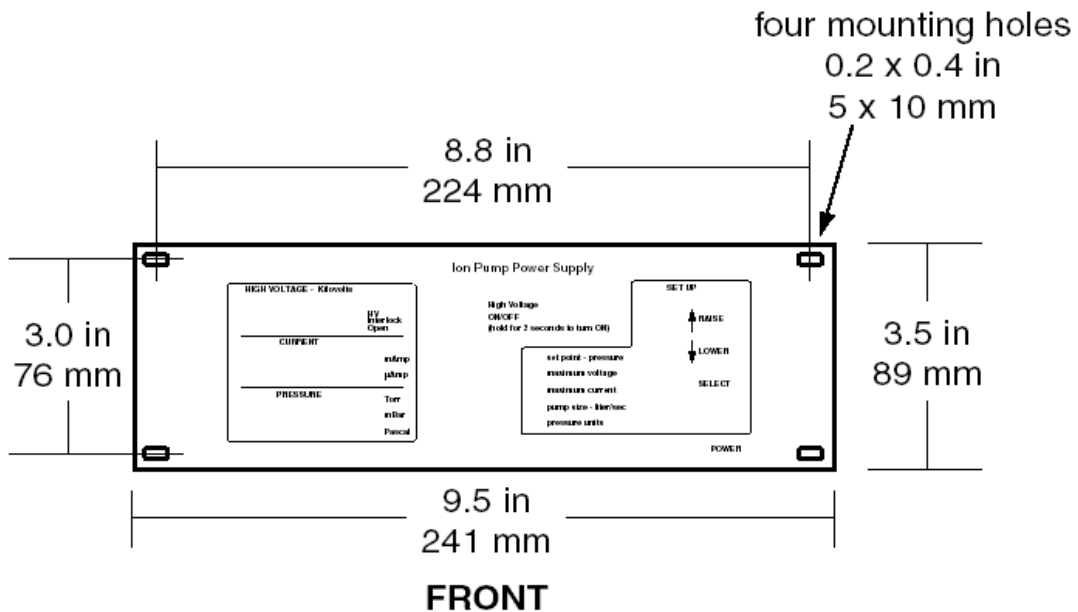
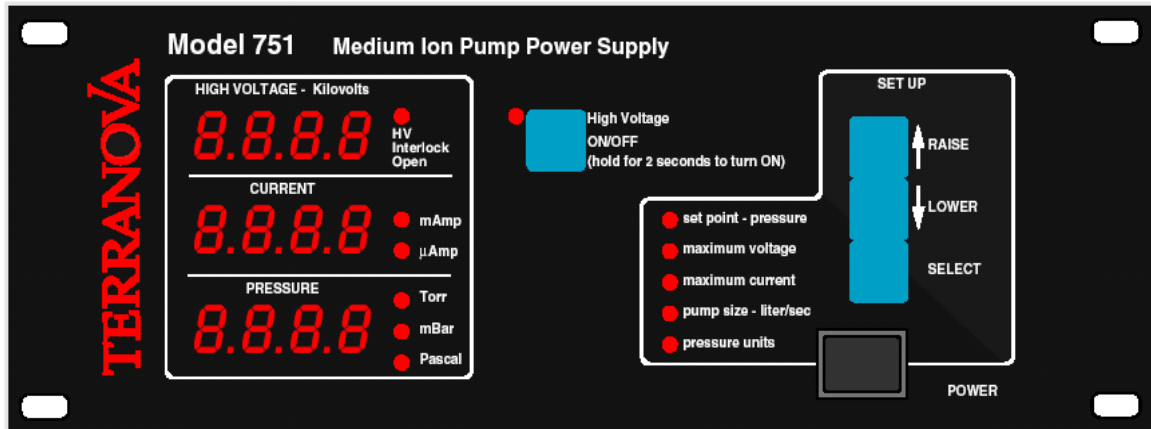

**Figure 6: Model 751 Front Panel & Mounting Dimensions**

## B. Front Panel Description and Preliminary Set Up

### 1. Displays:

There are three alphanumeric displays:

High Voltage: Polarity sign (+ or -) and 3 digits with decimal.

Current: 3 digits with decimal

Pressure: 2 digits with decimal plus exponent with sign

There are 12 LED indicators.

HV Interlock

HV On

Current (2): milliamp or microamp range

Pressure Units (3): torr or mbar or Pascal

Set Point Set Up or Activated

Maximum Voltage Set Up

Maximum Current Set Up

Pump Size Set Up

Pressure Units Set Up

### 2. Set-Up Keys

There are three Set Up keys provided

SELECT places the unit into Set Up Mode and activates the other two keys

RAISE ▲ increases the value of the selected parameter

LOWER ▼ decreases the value of the selected parameter

### 3. Power Switch

A rocker-type power switch is provided on the front panel. It is labelled with the international binary 0/1 notation: Binary zero (circle) depressed is OFF and binary 1 (bar) depressed is ON.

### 4. High Voltage Switch

A push button is provided to turn high voltage on and off. Turning high voltage on requires the operator to depress the button for 2 seconds (for safety reasons), while turning high voltage off is instantaneous.

### C. Initial Set Up

1. Turn on: When the power is initially turned on by depressing the bar side of the rocker type power switch, the Model 751 will cycle through a diagnostic exercise in the following sequence:

- a. All display segments will momentarily activate.
- b. All LED indicators will momentarily activate.
- c. The model number "751" will appear on the VOLTAGE display.
- d. The internal DIP switch setup will be displayed in the CURRENT display (see IV-C).
- e. The release version of the unit "N.NN" (e.g. 1.02) will appear on the pressure display.
- f. "OFF" will be displayed on the High Voltage display.

(Holding down the SELECT button during power-up will retain display of model #, DIP switch settings and release version until the SELECT button is released. This is for ease of interpretation.)

2. Set Up: After the turn on cycle described above, the parameter set up process is accomplished by 6 operations of the "SELECT" switch.

a. The first press of the "SELECT" button will allow the adjustment of the set point pressure, which is shown on the "Pressure" display. The default set point pressure is OFF and the range is  $0.1 \times 10^{-9}$  to  $1 \times 10^{-5}$  in the chosen units of pressure. Press the ▲ button to raise the set point pressure and press the ▼ button to lower the set point pressure.

#### SET POINT OPERATION

In operation, as the pressure falls in the ion pump, the set point relay goes to the 'ON' condition when the pressure is less than or equal to entered setting.

**Pressure Falling: (Set Point Relay 'ON' if  $P = \text{or} < \text{Setting}$ ).**

As the pressure rises, the set point relay goes to the 'OFF' position when the pressure is equal to or greater than 1.20 times the entered setting. This 20% hysteresis range is provided to avoid "chatter" in the set point relay at or very near the entered setting.

**Pressure Rising: (Set Point Relay 'OFF' if  $P = \text{or} > 1.2 \times \text{Setting}$ )**

Both Normally Open (NO, pin 9) and Normally Closed (NC, pin 2) terminals are provided on the Miscellaneous I/O Connector, see Section C2)

b. The second press of the "SELECT" button will allow the adjustment of the maximum voltage supplied by the Model 751, which is displayed on the "High Voltage" display. The default maximum high voltage is 7500 volts (displayed as +7.50 KV) and the range is 3500 volts to 7000 volts. Press the ▲ button to raise the maximum high voltage and press the ▼ button to lower the maximum high voltage.

c. The third press of the "SELECT" button will allow the adjustment of the maximum current supplied by the Model 751, which is displayed on the "Current" display. The default maximum current is 25 milliamps, and the range is 1 milliamp to 25 milliamps. Press the ▲ button to raise the maximum current and press the ▼ button to lower the maximum current.

d. The fourth press of the “SELECT” button will allow the choice of the pump size, (used in the calculation of pressure from the pump current), which is displayed on the “Current” display. The default pump size is 20 liters per second and the range is 0.1 liter per second to 999 liters per second. Press the ▲ button to raise the pump size and press the ▼ button to lower the pump size

e. The fifth press of the “SELECT” button will allow the choice of pressure units displayed by the Model 751, which is displayed on the “Pressure” display. The default pressure units are torr (displayed as tor) and the alternate choices are millibar (displayed as bar) and Pascal (displayed as pas). Press the ▲ button or the ▼ button to change the choice of pressure units.

f. The sixth press of the “SELECT” button will return the Model 751 to the “Operate” mode, in the transition, all display segments will momentarily be illuminated.

3. Re-setting Parameters to Default Values: The unit can be returned to default settings of parameters by turning the power switch OFF, then simultaneously depressing the raise (▲) and lower (▼) buttons on the front panel while turning the power switch ON. The unit will cycle through its normal turn-on diagnostic process (see C.1, above) and then the display will show “rst” and the unit will emit short ‘beeps’ until the reset is complete.

#### **D. Safety Considerations**

The primary safety hazard when operating high voltage power supplies such as the Model 751 is electrical shock. Electrical shock can result from contact with the AC line voltage, internal potentials in the control unit or the high voltage output of the unit itself. The high voltage output hazard can exist either from direct contact with the high voltage lead or as a result of loss of proper grounding of the unit or the pump.

#### **WARNING!**

**Always wait at least 15 seconds after turning OFF high voltage before working on either the Model 751 or the sputter-ion pump.**

**NOTE: In a properly operating Model 751, the absence of hazardous potentials on the high voltage output may be verified by reading the high voltage meter on the front panel.**

## E. Rear Panel

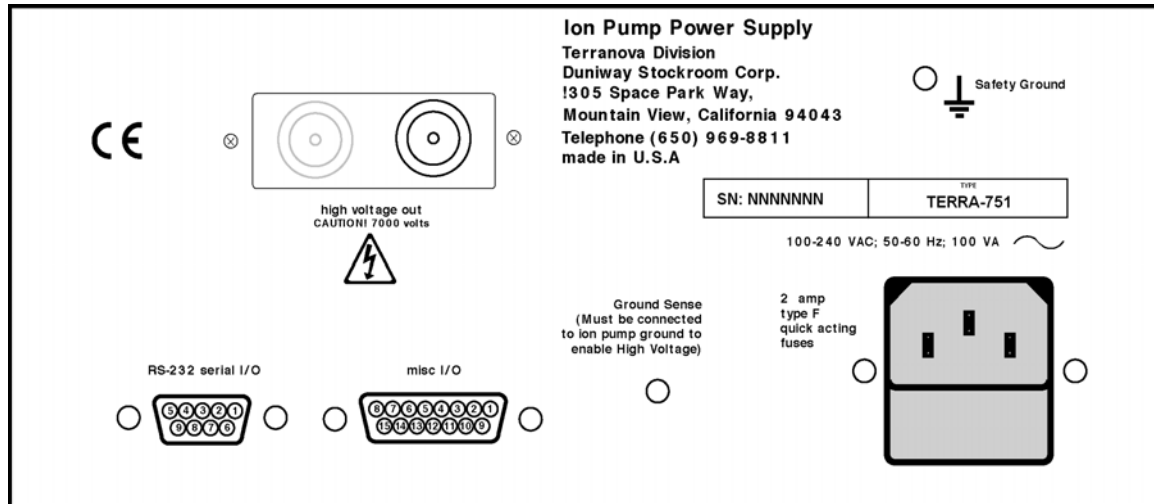

**Figure 7: Model 751 Rear Panel**

### Power Input/Fuse Module

The Power Input socket is a standard IEC 320 instrument power input receptacle. Replacement fuses are 2 amp type S slow Blow fuses. The Model 751 has a universal power supply which accepts 100 - 240 Volts, 50-60 Hz or DC.

### High Voltage Connector

The standard High Voltage output connector is a Kings-type 10 KV co-axial connector. Units are also available with two Kings-type connectors and one or two Fischer -type connectors. See Section IV-F, below for high voltage cable descriptions.

### Ground Sense Circuit Terminal

A Ground Sense Circuit Terminal is provided on the rear panel of the Terranova 751. It is an isolated 8/32 screw-lug. If the Ground Sense terminal and High Voltage cable shield are not properly connected to the vacuum system ground, the high voltage can not be turned on. See additional explanation immediately below in Section II-F.

### **Ground Lug**

A separate Safety Ground (Earth Ground) 8/32 screw-lug is also provided. This lug is permanently attached to the Model 751 chassis. See the explanation above before using this terminal.

### **Serial RS-232 D-9 Connector**

A D-9 connector is provided for the serial I/O signals. See section I-C for the pin-signal configuration.

### **Miscellaneous I/O D-15 Connector**

A D-15 connector is provided for the miscellaneous I/O signals. See section I-C for the pin-signal configuration.

## **F. Safety Interlock - Ground Sense Circuit Description and Procedure**

A Safety Interlock circuit has been incorporated into the Model 751 to reduce the risk of electrical shock in the case that proper grounding is lost. The required Ground return path is provided through shielding on the high voltage cable. See the discussion below.

### ***PROCEDURE:***

### **GROUND SENSE SAFETY WIRE**

1. Ensure that continuity exists between the high voltage output connector shell and the sputter-ion pump body.
2. Make a connection between the ground sense lug connector on the rear panel of the Model 751 (See Figure 2 - Photograph of Rear Panel) and any convenient fastener on the sputter ion pump body.
3. If there is a ground fault (open circuit), The High Voltage will be turned OFF and the Ground Sensing Circuit LED "HV Interlock Open" lamp on the front panel will be illuminated. To restore High Voltage, correct the grounding problem and press the High Voltage ON button on the front panel.

### **WARNING!**

**Under no circumstances should the ground sense strap be connected directly to the case of the Model 751. That would defeat the protection provided by this safety feature and may result in serious electrical shock hazard to personnel.**

## Discussion of the Ground-Sense Safety Circuit Operation

The Terranova Ground-Sense Circuit is provided to assure that the high voltage will be turned off if either the Ground-Sense connection or the High Voltage connection to the ion pump is broken or lost.

The Ground-Sense safety feature operates to allow the HV to operate when the Ground-Sense wire is connected between the Terranova 751 Ground-Sense terminal on the rear of the unit and the ion pump body; AND the high voltage cable ground shield is properly terminated both through the HV ion pump connector to the ion pump body and through the controller connector to the Terranova 751 chassis.

If either Ground-Sense or Ground Shield connections are interrupted at either end, the HV will automatically be shut off.

**NOTE:** \*A redundant ground connection, either intentional through a separate grounding wire or unintentional, through chassis contact with pump/system ground (as in mounting pump and control on the same conducting rack or cart), will defeat the HV turn-off portion of the Ground Sense safety circuit\*. See the table below for state conditions for all these alternatives.

Use of cables other than those approved by Duniway Stockroom Corp. could lead to operation problems of safety hazards.

741 Ground Sense Conditions				
Case	Ground Sense Line	HV Cable Ground	Redundant 741-Pump Ground	741 HV
1	N	N	N	OFF
2	Y	Y	N	ON
3	Y	N	N	OFF
4	N	Y	N	OFF
5	N	N	Y	OFF
6	Y	N	Y	ON*
7	N	Y	Y	OFF
8	Y	Y	Y	ON*

**Figure 8 - Terranova 751 Ground-Sense Conditions**

### G. Connection to Pump

The Model 751 is connected to a sputter-ion pump by means of a coaxial cable assembly. To see a list of cables, go to Section IV-E, or for more details, photographs, prices or special length cables, please call Duniway Stockroom Corp. or go to our web page at [www.duniway.com](http://www.duniway.com).

#### **PROCEDURE: CONNECTION TO THE PUMP**

1. Turn OFF the POWER switch on the front panel of the Model 751.  
(See Figure 6 - Front Panel Photograph)
2. Make or confirm the required ground connections to the Model 751 as described above in Section II-D.
3. Verify that (or set) the pump selection is set to the correct value for the sputter ion pump in use.
4. Verify that the high voltage polarity is correct for the pump in use. Positive (+) polarity is used for diode, noble diode and DI pumps while negative (-) polarity is used for triode and StarCell<sup>R</sup> pumps. If you have any questions about the type of pump you are planning to use, contact Duniway Stockroom Corp. immediately.
5. Attach the high voltage connector to the ion pump.
6. Connect the Kings-type, 10KV connector (control unit end of high voltage cable) to the high voltage output connector on the rear of the control unit.

#### **WARNING!**

**NEVER apply power to the Model 751 until proper grounding has been checked and verified.**

Now, rough pump the system to a pressure of  $10^{-3}$  torr or below. Turbo roughing is strongly recommended, however a cryosorption pumps or two stage oil sealed rotary pump or other roughing pump can be used with careful attention to technique and appropriate trapping of pump oils.

#### **CAUTION**

**At pressures below about  $1.5 \times 10^{-1}$  torr for most systems and pumps, the backstreaming of mechanical pump oil is a significant problem. High quality oil traps MUST be used.**

## III Operation

### A. Start-Mode Operation

1. Turn the POWER switch on the front panel to ON. No warm-up period is required.
2. When it is suspected or observed that the roughing system has reached its base pressure, the ion pump starting cycle can be started. **Note the maximum recommended operating pressures for various pump sizes listed in section II-A, above.**
3. Push the High Voltage switch and hold for two seconds. The High Voltage ON LED will be activated and the High Voltage display will show the voltage. The voltage will ramp up to the Maximum Voltage designated in the set-up procedure (or to some lower value determined by the load represented by higher pressure in the ion pump.) The Current and Pressure displays will remain off until several seconds have elapsed (to avoid displaying erroneous transient start up values).
4. When the initial voltage (at maximum or rising), current (falling) and pressure (falling) are observed to be improving, close the roughing valve.

If the voltage falls (meaning that current and therefore pressure is rising), reopen the roughing valve.

If the voltage increases or remains constant (pressure is decreasing or “holding”), leave the roughing valve closed.

#### *NOTE*

With a sputter ion pump, a modest rise in pressure is normal during the initial START. This is caused by heating of the pump components and is beneficial in outgassing the elements for later operation in the NORMAL mode.

5. Maximum Current (Imax) Operation: During Initial Set Up (Section II-C), the operator chooses a value for the maximum current (Imax) which the ion pump should be exposed to. This function is provided to limit the power input, especially to small pumps. In operation, if the pump current rises to Imax, the Terranova 751 automatically begins limiting power by incrementally reducing the high voltage applied to the ion pump. This incremental voltage reduction continues until the ion pump current stays below the Imax setting. If the ion pump current remains at or near the Imax setting for extended periods, the 751 goes into a cool-down mode (below).

6. Cool-Down Mode: If the ion pump current remains at or near the maximum current ( $I_{max}$ ) setting for a period of 10 minutes, the 751 automatically shuts OFF the high voltage to allow the ion pump to cool down. The high voltage stays off for 5 minutes and then comes back on. This cyclical process continues (10 minutes ON - 5 minutes OFF) for 5 cycles if the ion pump current stays at or near  $I_{max}$ . If the ion pump current goes significantly below  $I_{max}$  at any time during this process, the  $I_{max}$ /Cool-Down Mode will be re-started at the beginning. If the full 5 cycles are completed without significant ion pump current reduction, the 751 automatically goes into shut-down mode (below). A series of 'beeps' is emitted when the cool-down mode or shut-down mode is commenced.

The display shows "cdX" when the voltage goes off, where X is the cool-down cycle number, between 1 and 5. The unit emits X beeps when entering a cool-down cycle.

7. Shut-Down Mode: If the 751 goes through the full cool-down cycle, it goes into shut-down mode. The high voltage is turned OFF, a 5 second 'beep' is emitted and the display shows "sd".

In addition, if the high voltage output is shorted to ground, due to malfunction of the ion pump, cable or connector, the 751 will enter shut-down mode after 30 seconds have elapsed. The high voltage turns OFF, a 5 second 'beep' is emitted and "sd" is displayed.

To recover normal operation from shut-down, resolve the situation that led to shut-down and press the HV button on the front panel for 2 seconds.

8. Defeating Cool-Down/Shut-Down Modes: Operation of the Cool-Down and Shut-Down Modes can be accomplished by changing the internal DIP switch settings. See Section IV-D.

## **B. Normal Mode Operation**

Operation in the NORMAL mode is simple and automatic. As the pressure and current fall, the operating voltage approaches the open circuit value for the control unit; and the current is approximately proportional to pressure over a wide range of pressures.

Pressure at the pump inlet flange may be read directly on the "pressure" display of the front panel. (This assumes that the pump size in the selection mode has been made properly during set up.)

Alternately, if the current vs. Pressure relationship is known for the pump in use, current may be read directly and converted into a pressure reading.

## DISCUSSION OF THE TECHNIQUE

The current drawn in a sputter-ion pump is nearly proportional to pressure. For the Terranova 751 unit, the equation used for calculating pressure from current is:

$$P = (K \times I) / (S \times V),$$

where P is the pressure in Torr, K is a constant equal to 369.6, I is the current in amps, S is the Pumping Speed as entered during Set-Up in liters per second and V is the Voltage in volts as entered during Set-Up.

While it is true that the current drawn in a sputter-ion pump is nearly proportional to pressure over a wide range, there are limitations to the technique. Specifically:

1. The proportionality is only approximate.
2. At pressures less than  $1 \times 10^{-8}$  Torr, the current to the Penning discharge is multiple valued, displaying significant hysteresis. Thus the current drawn depends on whether the pressure is rising or falling.
3. Sharp points and edges, or flakes which may form with prolonged pump use, particularly in triode pumps, can add significant current, due to field emission, which is independent of the pressure. (These field emission points can be removed by "hi-potting" the pump, that is, by applying AC or DC voltages to the pump of at least twice the operating voltage, preferably with the pump magnets removed.)

For these reasons, the accuracy of the pressure as indicated by the ion pump current is no better than +/-20%, and that accuracy is only achieved in the pressure range between  $1 \times 10^{-7}$  Torr and  $1 \times 10^{-5}$  Torr.

For pressures below  $1 \times 10^{-8}$  Torr, a Bayard-Alpert ionization gauge is strongly recommended. The pressure indication on the Model 751 is semi-quantitative.

Note that for sputter ion pumps, it is possible to extrapolate the current value to extremely low pressures and obtain a "reading" for the pressure. This is subject to the same fundamental limitations indicated above, and is therefore not a reliable indication of pressure.

Note that these effects, while significant to the measurement of pressure, have only minor effects on the pumping efficiency, and for that purpose may be generally neglected.



**General format to set a value**

[start character][two byte address][two byte command mnemonic][:][value][,][checksum][cr]

Example to set the pump size to 20 liters per second

In RS-232/422 mode, checksum disabled:

Send:                    **\*PS:20<cr>**  
 Response:               **OK:20,cc<cr>**

In the RS-485 mode, checksum enabled:

Send:                    **\*05PS:20,00<cr>**  
 Response:               **05,OK:20,cc<cr>**

<b>Command</b>	<b>Description</b>	<b>Parameter</b>
UN	<b>Set</b> Pressure Units	Torr, mBar, Pascal
PS	<b>Set</b> Pump Size	NNN.N (liters per second)
HV	Turn HV On or OFF	On, Off
SP	<b>Set</b> Set Point	N.N e-X (0.0 is off)
MV	<b>Set</b> Max Volts	NN00 (will be rounded to the nearest 100 volts)
MC	<b>Set</b> Max Current	NN (1-25 mA)

**Figure 10: Serial Interface Parameter Control Command Format**

### D. Power Characteristics

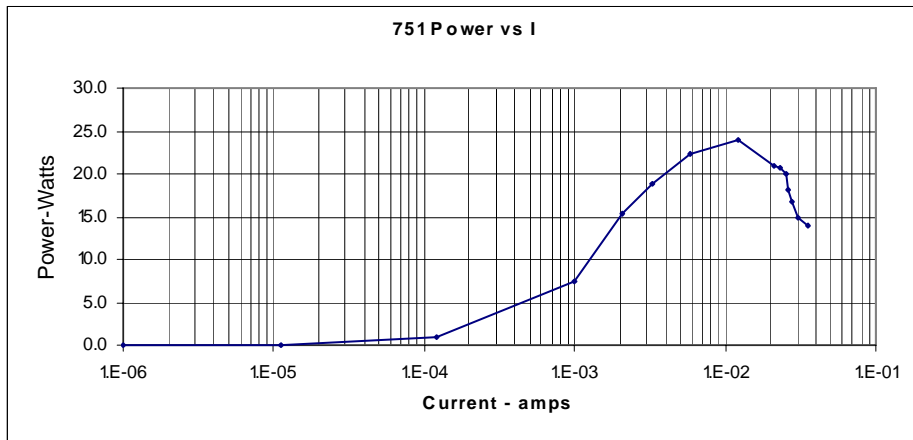

**Figure 11: Model 751 Power vs. Current**

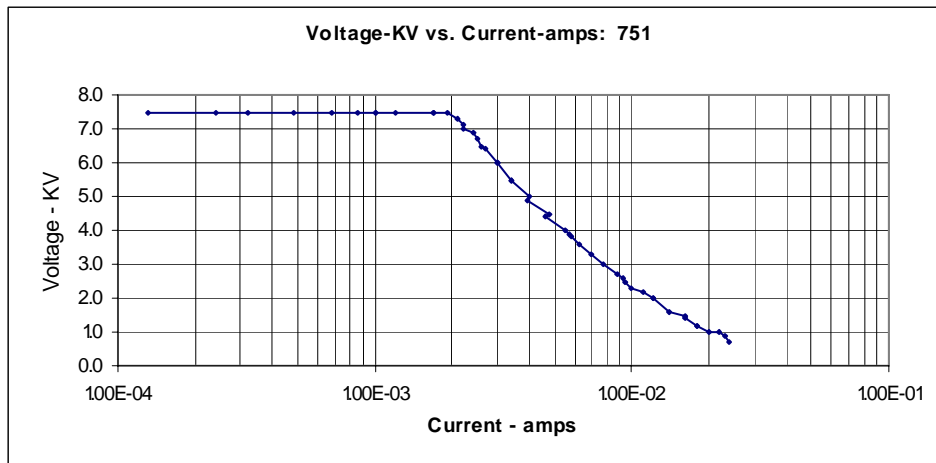

**Figure 12 Model 751 Voltage vs. Current**

# IV Maintenance

## A. 751 Block Diagram

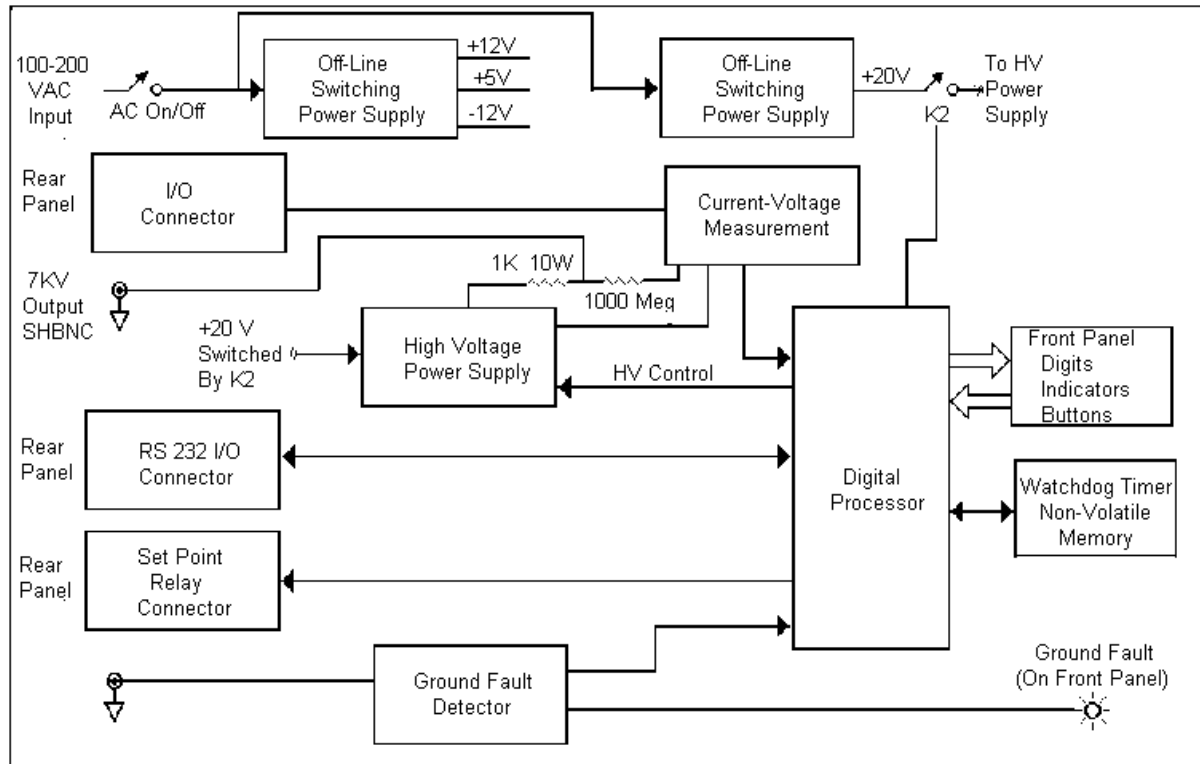

**Figure 13: Model 751 Block Diagram**

## B. Verification of Operation

### Terranova 751 --- Ion Pump Control-Display Units

This set of three procedures can be performed together sequentially or independently. For additional setup, operation and troubleshooting information, please see the "Operators Manual".

#### Power-On Initiation Cycle

When the unit is switched on with power applied, the display will cycle through the following sequence:

- 'BEEP' a) HV LED and HV LSB.All Segments ON briefly.
- b) All Display Segments ON.
- 'BEEP' c) All LEDs (except HV) ON
- 'BEEP' d) Configuration display
  1. Top Display – Model Number (751, etc.)
  2. Middle Display – Microswitch Set-Up (Typically 0000)
  3. Lower Display – Micro-Code Version # (3.00 for example)
- e) Ready: HV display reads OFF, Units LED ON as configured (torr, mbar, pascal)

#### Parameter Setup/Display

With power applied, subsequent presses of the "SELECT" button will result in a 'CHIRP', display the parameter and allow adjustment of the parameters as follows:

- a) Set Point: Press RAISE or LOWER until display shows "**1.0-7**"( $1.0 \times 10^{-7}$ )
- b) Maximum Voltage: Press RAISE or LOWER until display show "**5.00**"
- c) Maximum Current: Press RAISE or LOWER until display shows "**10**"
- d) Pump Size: Press RAISE or LOWER until display show "**2.0**".
- e) Pressure Units: Press RAISE or LOWER until display shows "**tor**"
- f) Unit returns to Ready state. (If left for more than 30 seconds, the unit automatically returns to the Ready state.)

#### Current Output Verification/Calibration

Use the "Calibration Plug" part number **10KV-1000M** supplied by Duniway Stockroom Corp.

With the High Voltage turned OFF, with the unit set up with the parameters listed in item 2 above, attach the calibration plug to the High Voltage output connector on the back of the unit. (If the unit has a "ground sense" terminal on the rear panel, attach it to a ground lug.)

Turn on Power and the High Voltage and allow a few seconds for the unit to stabilize.

The displays should read:

- a) Top, High Voltage-Kilovolts, **5.00**, +/- 0.00
- b) Middle, Current, **5.00** microamps, +/- 5%\*
- c) Bottom, Pressure, **1.8-7** ( $1.7 \times 10^{-7}$ ) torr, +/- 5%\*

\* +/- 5% accuracy is due to buildup of tolerances in Calibration Plug and unit circuits.

## DISCUSSION OF THE TECHNIQUE

### CALIBRATION PLUG

The resistor built into the "Calibration Plug" is 1000 Meg-ohm ( $10^{+9}$  ohms). The current drawn through this resistor follows ohm's law,

$$I = V/R$$

So, for the setup example above,

$$I = 5 \times 10^{+3} \text{ volts} / 10^{+9} \text{ ohms} = 5 \times 10^{-6} \text{ amps}$$

### ION PUMP CURRENT/PRESSURE RELATIONSHIP

The current drawn in a sputter-ion pump is nearly proportional to pressure. For the Terranova 751 unit, the equation used for calculating pressure from current is:

$$P = (K \times I) / (S \times V),$$

where P is the pressure in Torr, K is a constant equal to 369.6, I is the current in amps, S is the Pumping Speed in liters per second, as entered during Set-Up, and V is the Voltage in volts as entered during Set-Up.

For the example Setup above:

$$P = (369.6 \times I) / (2.0 \times 5000) = 3.7 \times 10^{-2} (I)$$

or

$$P = (3.7 \times 10^{-2}) \times (5 \times 10^{-6}) = 1.8 \times 10^{-7} \text{ torr}$$

## C. Diagnosing Ion-Pumped Vacuum Tube/System Condition Using the Terranova 751 Controller

### Condition A: Hard Vacuum

1. This desired condition is indicated by low current/pressure readings. Depending on the size of the ion pump, the current should be a few microamps or less. For example, the I/P in amps per torr is approximately 10 times the pumping speed of the pump. For a 2 liter per second ion pump, I/P should be approximately 20 amps per torr. A pump current of 2 microamps ( $2 \times 10^{-6}$  amps) would indicate a pressure of  $1 \times 10^{-7}$  torr. For another example, a pressure of  $1 \times 10^{-8}$  torr would yield a pump current of 0.2 microamps ( $2 \times 10^{-7}$  amps).
2. Small ion pumps sometimes require significant time for the discharge to strike at hard vacuum. This determination should be made only after allowing several minutes to elapse after first applying the ion pump voltage.
  - a. If this condition is suspected, and the pump is accessible, lightly tap the metal body of the ion pump with a non-magnetic object, such as a pen or screw-driver handle, to encourage starting of the pump.
  - b. Another method of starting the ion pump discharge at hard vacuum conditions, is to temporarily apply a higher voltage, by the procedure described below in Condition B-1.
  - c. The starting of the discharge will be indicated by a temporary surge of current, which will then gradually decline to the expected value.
  - d. When the ion pump discharge starts, return the MAXIMUM VOLTAGE to its operating value of 4KV. This is best done without turning the High Voltage OFF!
3. Low or no current at operating voltage (4KV) can also indicate the Down to Air condition, see Condition B, below.

### Condition B: Down to Air

1. Low or no ion pump current at operating voltage (4KV) can occur if the tube/system is down to air, that is, at high or atmospheric pressure due to a significant leak. This condition can be tested for and verified by operating the pump briefly at higher than operating voltage. Follow the steps below:
  - a. With the High Voltage OFF, press the ADJUST button twice to enter the High Voltage adjust mode (the red LED marked "Maximum Voltage" will be illuminated.)
  - b. Press the RAISE button until the display shows 7.50 (7500 volts).
  - c. Press the ADJUST button four more times to return to the OPERATE mode.
  - d. Press and hold the High Voltage On/Off button until the display begins to show the voltage and current.
2. As the voltage rises toward 7.5KV (7500 volts), the current pressure display will fluctuate and you should hear a "sizzling" or "tickling" sound from the ion pump due to high voltage breakdown inside the pump.
3. DO NOT leave the High Voltage on in this condition for more than a few seconds at a time, because damage could occur to the internal insulating surfaces of the ion pump.

### **Condition C: Poor Vacuum**

If the operating current is steady at a higher than expected value, for example, more than 10 microamps ( $1 \times 10^{-5}$  amps) for a 2 liter per second ion pump, the vacuum in the tube/system is poor. Further tube/system diagnosis, leak checking and repair should be undertaken.

### **Condition D: Pump Leakage Current**

If the ion pump current is a steady or fluctuating around a few microamps, and it is believed that the tube/system is under hard vacuum, there may be leakage current in the ion pump. The following steps can be taken to resolve this condition.

1. Insulator External Surface Contamination: After turning the High Voltage OFF, remove the High Voltage Connector from the ion pump. Using a lint-free cloth or paper wipe and some solvent such as alcohol, gently clean the insulator surface of the High Voltage Feedthrough. When the surface is clean and dry, re-attach the High Voltage Connector and resume operation.
2. Field Emission Leakage Current: Follow the steps outlined in Section III-F above to diagnose and fix this condition.
3. If neither of these steps reduces the current, it is most likely truly due to ion current related to slightly elevated pressure in the tube/system.

### **Additional Information**

If you need additional information, please call Duniway Stockroom at 1-800-446-8811 or go to our web-site, [www.duniway.com](http://www.duniway.com). On our web-site, under "DOCUMENTS", you will find on-line versions of the Terranova 751 Manuals, plus more information on operating ion pumps.

## D. Trouble Shooting

<b>Problem</b>	<b>Possible Cause</b>	<b>Remedy/Diagnostic</b>
Unit will not turn on	Input fuses are open	Check fuses at AC input connector; missing, blown?
Unit will not turn on	Internal connector to power switch is not in place	Disconnect AC power cord, remove cover and verify that J10 is connected; J10 is located near rear-left side
Unit will not turn on	AC outlet has no power	Verify AC outlet power; 100 to 240 VAC, 47-63 Hz
Unit will not turn on	AC line cord is defective	Check continuity of AC line cord
Unit 'beeps' at turn-on, but display is dark	Internal connector to front panel is not connected	Disconnect AC power cord, remove cover and check ribbon-cable connector to display
Unit turns on, but display has random LED segments lit and doesn't respond	Microprocessor is not operating	Disconnect AC power cord, remove cover and verify that U1 and U2 are properly seated/socketed
Some LEDs or display segments don't light	LED component is defective	Return unit to Duniway Stockroom Corp. or request replacement display board
No beeps or response when any front panel buttons are pushed	Internal connector to front panel is not connected	Disconnect AC power cord, remove cover and check ribbon-cable connector to display

<b>Problem</b>	<b>Possible Cause</b>	<b>Remedy/Diagnostic</b>
No beeps or response when one front panel button is pushed, others OK	Defective button/switch	Return unit to Duniway Stockroom Corp. or request replacement display board
High voltage doesn't turn on when HV button is pushed	Ground-Sense Safety interlock is open, or High Voltage Ground Shield is open or unit is in Remote HV Control Mode	Check isolated Ground Sense connector on rear of unit for proper connection to ground. Check HV cable shield connections. Check DIP switch settings for proper configuration.
High voltage LED turns on, but voltage shows zero, pump connected	HV output is shorted	Remove HV connector from ion pump, try again
High voltage LED turns on, but voltage shows zero, pump not connected	Internal HV power supply not connected	Disconnect AC cord, remove cover and verify connection of J4 and J1 on HV board
High voltage LED turns on, but voltage stays near zero, pump connected/not connected	Plus/Minus 15 volt supplies are defective	Disconnect AC cord, remove cover and verify +/- 15 volts on E1 and E2, front-left. If defective, return unit to Duniway Stockroom Corp. for repair
High voltage LED turns on, but current stays near zero, pump connected	Pressure below detectable level.	No action required
High voltage LED turns on, but current stays near zero, pump connected	Cable to ion pump is open or not connected	Turn 751 off, disconnect HV cable, check continuity of both center conductor and shield.

<b>Problem</b>	<b>Possible Cause</b>	<b>Remedy/Diagnostic</b>
High voltage rises above and stays above set value	HV sense resistor is broken	Disconnect AC cord, remove cover and verify resistor (R16) is connected between HV coaxial connector center conductor and HV power supply
High voltage rises above and stays above set value	Ground connection is missing on HV power supply	Disconnect AC cord, remove cover and verify connection from TB4 on HV supply and chassis
RS232 communications don't respond	Tx and Rx are inverted	Invert connections to Tx and Rx on serial I/O cable connector
Set point relay contacts don't toggle	Contacts are welded together due to excess current or transients	Disconnect AC cord, remove cover and replace relay; add transient absorber to relay load.
Error Codes	<p><b>Err2</b></p> <p><b>Err3</b></p> <p><b>Err4</b></p> <p><b>Err5</b></p> <p><b>Err6</b></p>	<p>HV Exceeded 8KV; Recover</p> <p>Illegal Operation</p> <p>Attempt to change setup parameter while in Mode 2 HV Remote</p> <p>Attempt to turn on HV with Interlock 1 fault (J9-8)</p> <p>Attempt to turn on HV with Interlock 2 fault (J9-5)</p>

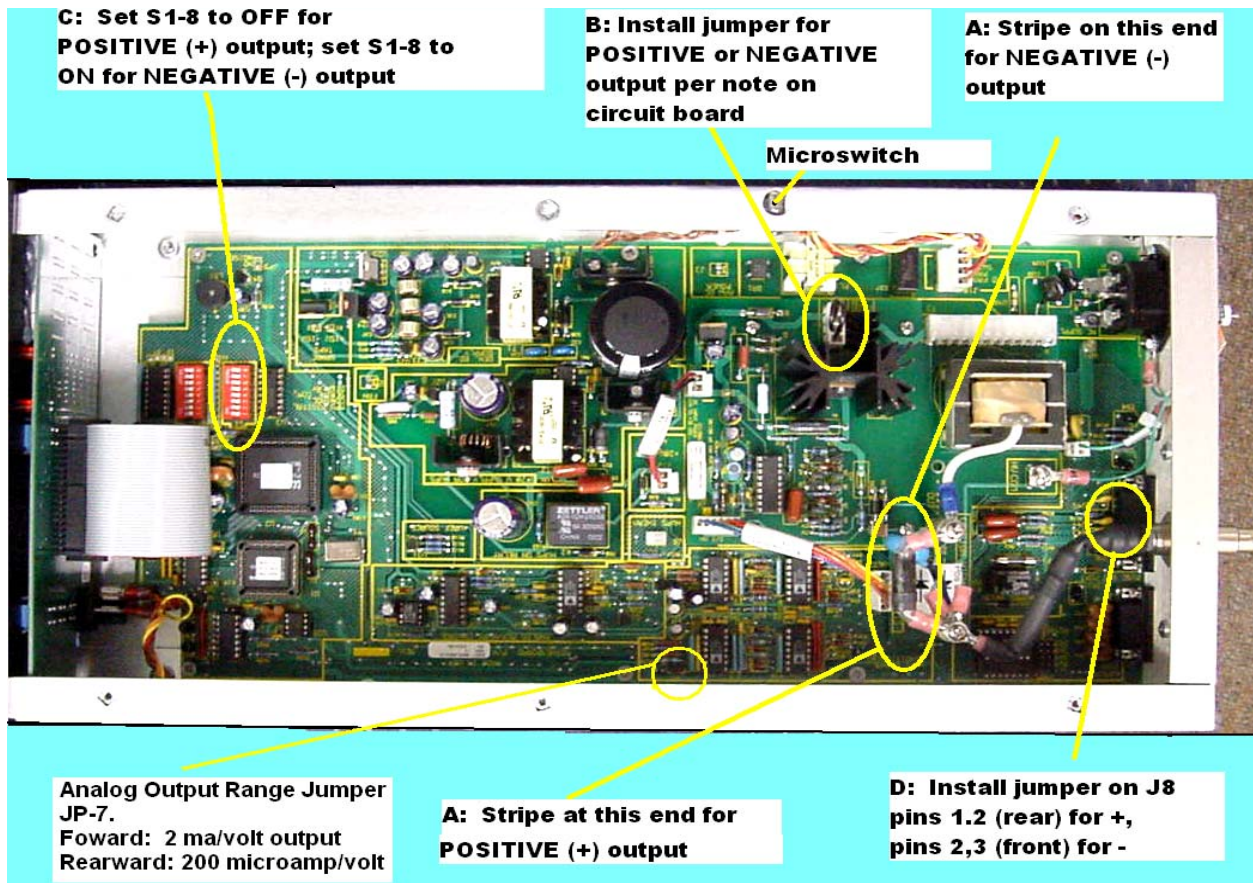

**Figure 14: Model 751 Top View, Cover Removed (Front:Left -- Rear:Right)**

(Note Power Interlock Micro-Switch at Top of Photo)

### **E. High Voltage Output Polarity Change Procedure**

1. Remove the AC Power Cord
2. Remove the top cover (6 Phillips Head screws)
3. Make the 4 Step Polarity Change (See Figure 14 for reference letters)

A. High Voltage Diode: Locate the High Voltage Diode mounted with screws through lugs on the top of two ceramic stand-offs (Figure 14, Oval A). The diode has a stripe around one end. When the diode is mounted with this stripe toward the left side of the 751 (top of Figure 14), the unit is configured for negative (-) high voltage output. When the diode is mounted with the stripe toward the right side of the 751 (bottom of figure 14), the unit is configured for positive (+) high voltage output. See the labels on Figure 14 to verify the instructions.

Remove the two screws from the high voltage diode lugs, being sure to retain the screws and/or washers from dropping into the interior of the unit. Flip the High Voltage Diode over to obtain the direction for the desired high voltage polarity. Replace and tighten the screws through the lug and into the top of the stand-off.

B. Polarity Jumpers: Locate the High Voltage Polarity jumpers (Figure 14, Oval B). Note the label on the printed circuit board beneath the two jumpers. "Select Output Polarity". There are two jumper positions: J3 NEGATIVE for negative (-) high voltage output polarity and J-2 POSITIVE for positive (+) high voltage output polarity. Place/verify that the 4-pin jumper is in the correct position to correspond with the placement of the High Voltage diode in step A, above.

C. DIP Switch Settings: Locate the DIP switch S1 (Figure 14, Oval C). Switch S1 is the switch toward the back of the unit labelled "S1". The individual switches on Switch S1 are labelled 1 through 8. Locate switch S1-8. For Positive High Voltage Output, switch S1-8 should be in the OFF position. For Negative High Voltage Output, switch S1-8 should be in the ON position. Switch S1-8 controls the + and - sign on the high voltage display.

D. Miscellaneous I/O Jumpers: Locate jumper JP-8 inside the rear panel near the Miscellaneous I/O plug (see Oval D.) For Positive High Voltage Polarity, connect pins 1 and 2 of JP-8. For Negative High Voltage Polarity, connect pins 2 and 3 of JP-8.

See Section IV-G below for other DIP switch settings.

Finally, verify that all four components (High Voltage Diode, Polarity Jumper, Dip Switch and Misc. I/O jumper) are set consistently to the voltage polarity required for ion pump operation. See Section II-A for ion pump voltage polarity requirements.

## **F. Analog Output Range Settings**

The Analog Output Range setting is controlled by Jumper JP-7 (see Figure 14 above). The Analog Output signal is 0 - 10 volts, available on pin 12 of the Miscellaneous I/O Connector. There are two User Selectable ranges available:

200 microamps per volt to 2000 microamps  
2 milliamps per volt to 20 milliamps (default)

To change the range: (after turning off the unit and removing the power cord)

1. Locate Jumper JP-7 on the right side of the main printed circuit board. JP-7 is a black rectangular component accessible from the top of the unit. The default position is forward (2 ma/volt). The jumper has 2 male pins, the base has three female sockets.
2. Pull the Jumper upward to remove it from its socket on the printed circuit board.
3. Replace the jumper in its new location.

## G. Internal DIP Switch Settings

There are two internal DIP switches located near the front of the main printed circuit board inside the unit. (See Figure 14, rectangle marked C.)

DIP Switch S1 NOTE: Remove the power cord before opening the unit.  
 The following shows the functions and default values for DIP Switch S-1. The factory default settings are all OFF for this switch. The settings of this switch are displayed in hexadecimal format on the right two digits of the CURRENT display during start-up.

- S1-1 Communications Protocol; Default OFF=RS-232/422; ON=RS-485.
- S1-2 Power Loss Restart; Default OFF=Disabled; ON=Enabled.
- S1-3 \* Remote HV Control Mode Set-Up; Default OFF=Disabled; ON=Enabled.
- S1-4 \* Remote HV Control Mode Set-Up, Default OFF=Disabled; ON=Enabled.
- S1-5 Factory Diagnostic, Pascal Units Only; Default OFF=Disabled; ON=Enabled.
- S1-6 Defeat Cool-Down/Shut-Down; Default OFF=Disabled; ON=Enabled
- S1-7 Communications Checksum; Default OFF=Disabled; ON=Enabled
- S1-8 High Voltage Polarity Display; Default OFF=Positive (+), ON=Negative (-)  
 (Note: For Remote HV Control Mode Set-Up and Operation, call Technical Support)

**Figure 15: DIP Switch - S1 - Settings**

### DIP Switch S2

The switches on DIP switch S2 are used to set up the Offset for residual current and the RS-485 address in 5-bit binary format. The following table shows the functions and default values for DIP Switch S2. The settings of this switch are displayed in 5-bit binary format on the three digits of the CURRENT display during start-up.

- S2-1 Residual Current Offset=0.1 microamp; Default=OFF\*
- S2-2 Residual Current Offset=0.2 microamp; Default=OFF\*
- S2-3 Residual Current Offset=0.4 microamp; Default=OFF\*
- S2-4, LSB of RS-485 address in 5-bit binary; Default=ON
- S2-5, Second bit of RS-485 address in 5-bit binary; Default=OFF
- S2-6, Third bit of RS-485 address in 5-bit binary; Default=ON
- S2-7, Fourth bit of RS-485 address in 5-bit binary; Default=OFF
- S2-8, MSB of RS-485 address in 5-bit binary; Default=OFF

**Figure 16: DIP Switch S2 Settings**

[NOTE: The default address for RS-485 is 5 (Right-Shifted 5-bit binary = 00101); this gives a range of 32 possible RS-485 addresses from 0 to 31. Also, DIP switch S1-1 must also be ON to enable RS-485 communications.] (\*Residual Current Offset function is provided to mask residual current which may build up due to aging and dust accumulation of the unit. The three switches are additive and provide up to 0.7 microamps of residual current offset (all three switches 'ON'). For further details, please call Duniway Stockroom Corp.)

## H. Fuses:

The fuses are located in the power input module on the back panel.

There are two fuses: 2 amp, type S, Slow Blow.

Replacement types are:  
 Bussman GDC-2A or  
 Littlefuse 218 002

## I. High Voltage Cables -- From: Model 751 - Kings Type - 10KV to: Ion Pump

<u>Pump End Connector</u>	<u>Cable Part Number</u>
Standard Varian	Standard A-110-10
Standard Varian	Bakeable A-210-10
Varian StarCell <sup>R</sup>	Standard S-110-10
Varian StarCell <sup>R</sup>	Bakeable S-210-10
Varian Mini	Standard M-110-10
Varian Interlock	Bakeable FS-210-10
P-E/Ultek	Standard P-110-10
P-E/Ultek	Bakeable P-210-10

Duniway Stockroom Corp. has the parts and knowledge to build a large variety of cables:

Hybrid Vendor Cables  
 Virtually Any Length  
 Bakeable - Non- Bakeable  
 Custom Coax Wire  
 Custom Shielding

Duniway Stockroom Corp. also supplies High Voltage Feedthroughs for all the common ion pumps; as well as rebuilding services and parts

For more details, prices or special cables, please call Duniway Stockroom Corp. or go to our web page at [www.duniway.com](http://www.duniway.com).

## V Warranty & CE Declaration

*Terranova products of Duniway Stockroom Corp. are warranted to be free of defects in material and workmanship for a period of one year from the date of shipment. At our option, we will repair or replace products which prove to be defective during the warranty period. Liability under this warranty is limited to repair or replacement of the defective items. Shipping damage is excluded from the scope of this warranty. Gauge tubes of all types are excluded from this warranty.*

*Terranova products are warranted not to fail to execute programming instructions due to defects in materials and workmanship. If Duniway Stockroom receives notice of such defects during the warranty period, Duniway Stockroom will repair or replace firmware that does not execute its programming instruction due to such defects. Duniway Stockroom does not warrant that the operation of the firmware or hardware will be uninterrupted or error-free.*

*If this product is returned to Duniway Stockroom for warranty service, Buyer will pre-pay shipping charges and will pay all duties and taxes for products returned to Duniway Stockroom. Duniway Stockroom will pay for return of products to Buyer, except for products returned to a Buyer from a country other than the United States.*

*LIMITATION OF WARRANTY: The foregoing warranty does not apply to the defects resulting from:*

- 1. Improper or inadequate maintenance by Buyer;*
- 2. Buyer-supplied interfacing;*
- 3. Unauthorized modification or misuse;*
- 4. Operation outside of the environmental specifications of the product; or*
- 5. Improper site preparation and maintenance.*

*THE WARRANTY SET FORTH ABOVE IS EXCLUSIVE AND NO OTHER WARRANTY, WHETHER WRITTEN OR ORAL, IS EXPRESSED OR IMPLIED. DUNIWAY STOCKROOM DISCLAIMS ANY IMPLIED WARRANTIES OF MERCHANTABILITY AND FITNESS FOR A PARTICULAR PURPOSE.*

*EXCLUSIVE REMEDIES: The remedies provided herein are Buyer's sole and exclusive remedies. In no event will Duniway Stockroom be liable for direct, indirect, special, incidental, or consequential damages, including loss of profits, whether based on contract, tort, or any other legal theory.*

# DECLARATION OF CONFORMITY

---

**We, Duniway Stockroom Corp., declare under our sole responsibility, that the following products, displaying the CE mark on the rear panel:**

Model 908A Dual Capacitance Diaphragm Gauge Controller  
Model 926A Dual Convection Gauge Controller  
Model 751 Ion Pump Control Unit

**to which this declaration relates, are in conformity with the following standards or normal documents**

EMC Directive (89/336/EEC//93/68/EEC)  
Electromagnetic Compatibility  
Standards: EN 50081-1: 1992, EN 50082-1: 1993



Low Voltage Directive (73/23/EEC//93/68/EEC)  
Electrical/Technical Safety  
Standard: EN 61010-1: 1993/A2: 1995

**following the provisions of the EMC directive (89/336/EEC)**

---

## **UL and CSA Listing**

Safety of Electrical Equipment for Laboratory Use  
UL61010A-1, Issued 2002/01/30  
CAN/CSA C22.2 No. 1010.1-92, 97



---

March, 2004

**by: Sherman Rutherford**  
Compliance Manager

Duniway Stockroom Corp.  
1305 Space Park Way  
Mountain View, California 94043

**rev053105sr**